



# ELDALE

## MACHINE & TOOL

**MANUFACTURERS OF HUB & SPINDLE ASSEMBLIES**



3 Industrial Drive, Elmira, Ontario N3B 2S1

P. (519) 669.5195

F. 1.800.572.6796

E. [sales@eldalemachine.com](mailto:sales@eldalemachine.com)



# ELDALE MACHINE & TOOL LTD. COMPANY PROFILE



## Manufacturing Hubs & Spindles for Agricultural Use

Eldale Machine & Tool Ltd. was founded in 1976 to manufacture hubs and spindles for agricultural original equipment manufacturers (OEM). The company has grown with its customers from a two-man operation to a fully equipped machine shop with modern CNC machines. In 2001, the company expanded to its larger facility in Elmira, Ontario and currently has ISO 9001:2015 certification.

The product line has expanded over the years to include hubs and spindles from 1,000 lbs. to 40,000 lbs capacity as well as custom machined parts. Uses include small utility trailers, farm wagons, manure handling equipment, grain carts, forestry and mining equipment, as well as sod and turf grass applications. Hubs may be modified to suit custom applications such as turntables, coulter hubs, pivot points and many industrial applications. Custom repairs and tractor spindle repairs are done on site.



**ELDALE**  
MACHINE & TOOL

3 Industrial Drive  
Elmira, ON  
N3B 2S1  
Tel. (519) 669-5195  
Fax (519) 669-5197  
Email: [sales@eldalemachine.com](mailto:sales@eldalemachine.com)  
[www.eldalemachine.com](http://www.eldalemachine.com)

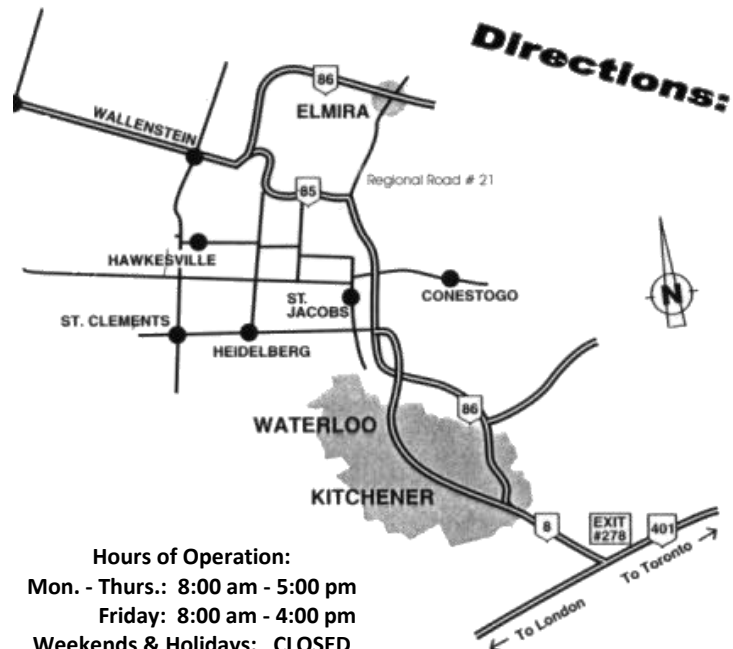

**Hours of Operation:**  
Mon. - Thurs.: 8:00 am - 5:00 pm  
Friday: 8:00 am - 4:00 pm  
Weekends & Holidays: CLOSED

# CONTENTS

ELDALE MACHINE & TOOL LTD. COMPANY PROFILE.....	2
GUARANTEE.....	4
HUB SPECIFICATIONS.....	5
INFORMATION REQUIRED FOR REPLACEMENT HUBS.....	5
SPINDLE MATERIAL SPECIFICATIONS.....	6
SPECIAL SPINDLE REQUEST.....	6
<b>4 &amp; 5 BOLT RECREATIONAL</b>	
# 1000 SERIES.....	7
# 1100 SERIES.....	8
# 1750 SERIES.....	9
<b>4 BOLT AGRICULTURAL</b>	
# 1250 (411) SERIES.....	10
# 1500 SERIES.....	11
# 2400 SERIES.....	12
<b>5 BOLT AGRICULTURAL</b>	
# 2500 SERIES.....	13
# 1800 SERIES.....	14
# 3000 SERIES.....	15
# 4500 SERIES.....	16
<b>6 BOLT AGRICULTURAL</b>	
# 2800 SERIES.....	17
# 4000 SERIES.....	18
# 5000 SERIES.....	19
# 5000B SERIES.....	20
# 6000 SERIES.....	21
<b>8 BOLT HEAVY PICK UP</b>	
# 5000-8 SERIES.....	22
<b>8 BOLT AGRICULTURAL</b>	
# 5500 SERIES.....	23
# 6500 SERIES.....	24
# 8000 SERIES.....	25
# 10000 SERIES.....	26
# 12000 SERIES.....	27
<b>10 BOLT AGRICULTURAL</b>	
# 871 (12000) SERIES.....	28
# 873 (15000) SERIES.....	29
# 16000 SERIES.....	30
# 16000 HD SERIES.....	31
# 20000 SERIES.....	32
# 891 SERIES.....	33
# 991 SERIES.....	34
# 25000 SERIES.....	35
<b>12 BOLT AGRICULTURAL</b>	
# 35000 SERIES.....	36
<b>MISCELLANEOUS</b>	
BRAKE DISC FOR HUBS.....	37
SPINDLE AND TANDEM TUBE.....	38
TRACTOR SPINDLE & REPAIR KITS.....	39
ELDALE # 2500 COULTER SPINDLES.....	40
ELDALE # 2500 COULTER SPINDLES.....	41
# 2500 COULTER SERIES.....	42
# 3000 COULTER SERIES.....	43

# GUARANTEE

Stated hub capacities are based on 20,000-mile B10 bearing life and 14,000 psi maximum fiber stress on the spindle in the bearing and seal area at tractor speeds up to 20 mph. The use of these products for other than free rolling applications, such as rough terrain, hill sides, tandem assemblies, side load or duals etc., will reduce the stated capacities by 25%. Hubs and spindles are guaranteed against any defect in workmanship and material under normal use and service for one year from the date of purchase. Our obligation under the guarantee is limited to replacement or repair of the defective part, based on satisfactory proof of the condition or cause of defect and does not cover consequential damages to property or persons. Any parts or products damaged due to accident, abuse, misuse or improper installation are not covered by the guarantee.

We reserve the right to make improvements, changes in specifications or materials without notice.

Determinations of required spindle strength inboard of the seal seat is the responsibility of the buyer.

All hubs must be packed with grease during assembly and lubricated every 1000 hours or annually thereafter (as recommended by S.A.E. Standards for lubricating industrial machinery) to assure longer bearing life.

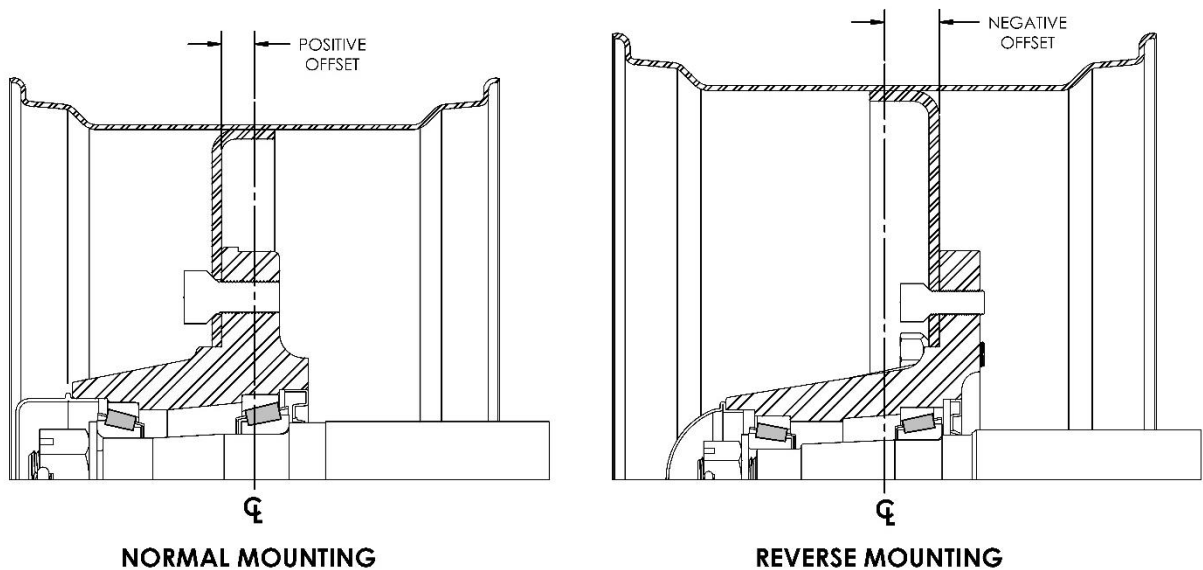

**POSITIVE OFFSET: (INSET)** This distance is termed positive when the mounting face is outboard of the rim centerline.

**NEGATIVE OFFSET: (OUTSET)** This distance is termed negative when the mounting face is inboard of the rim centerline.

# HUB SPECIFICATIONS

## INFORMATION REQUIRED FOR REPLACEMENT HUBS

ITEM		
A	Manufacturer (on back of hub)	
B	Part No. (on back of hub)	
C	Number of bolts / Bolt circle	
D	Bearing numbers	INNER
		OUTER
E	Spacing between cups in hub	
F	Seal number (O.D. & I.D)	

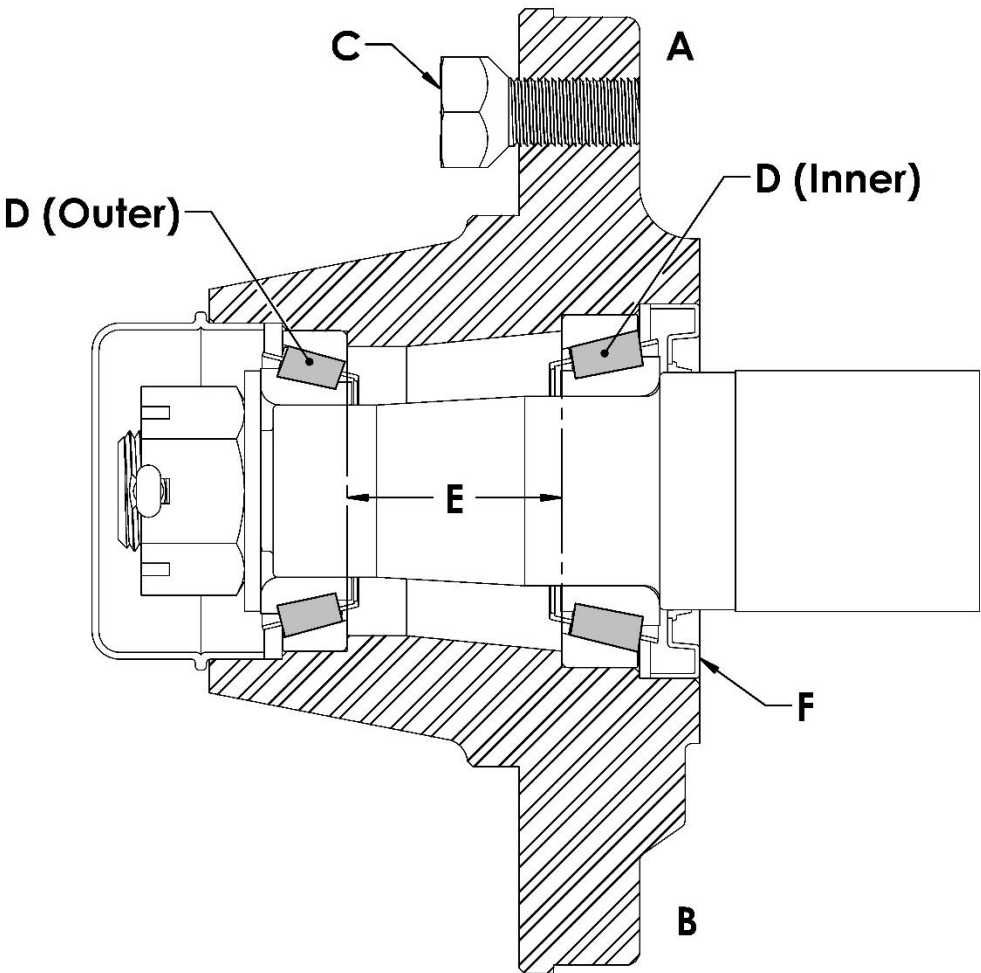

# SPINDLE MATERIAL SPECIFICATIONS

		MATERIAL	YIELD	TENNSILE
Standard Spindle Material:	Hot Roll	HR1045	59,000	98,000
	Cold Roll	CR1045	90,000	103,000
Special Order:	Cold Roll	SP/1144	97,000	114,000
	HTSR	4140	130,000	150,000

## SPECIAL SPINDLE REQUEST

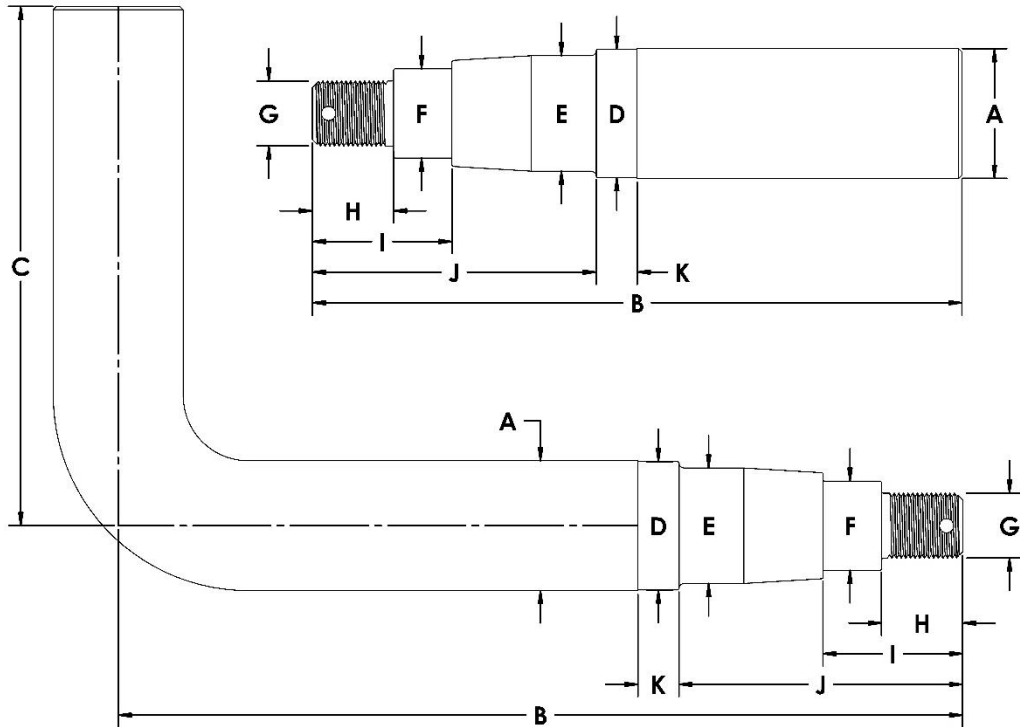

CUSTOMER NAME				
TO FIT HUB NO.				
SPINDLE STYLE				
DIMENSIONS	A		G	
	B		H	
	C		I	
	D		J	
	E		K	
	F			
COMMENTS				

# # 1000 SERIES

	BOLT CIRCLE	PILOT
4 BOLT	4"	2.500"
4 BOLT	4.250"	2.500"
5 BOLT	4.500"	2.500"
5 BOLT	100 MM	2.500"

MAXIMUM WHEEL SIZE 12" DIAMETER

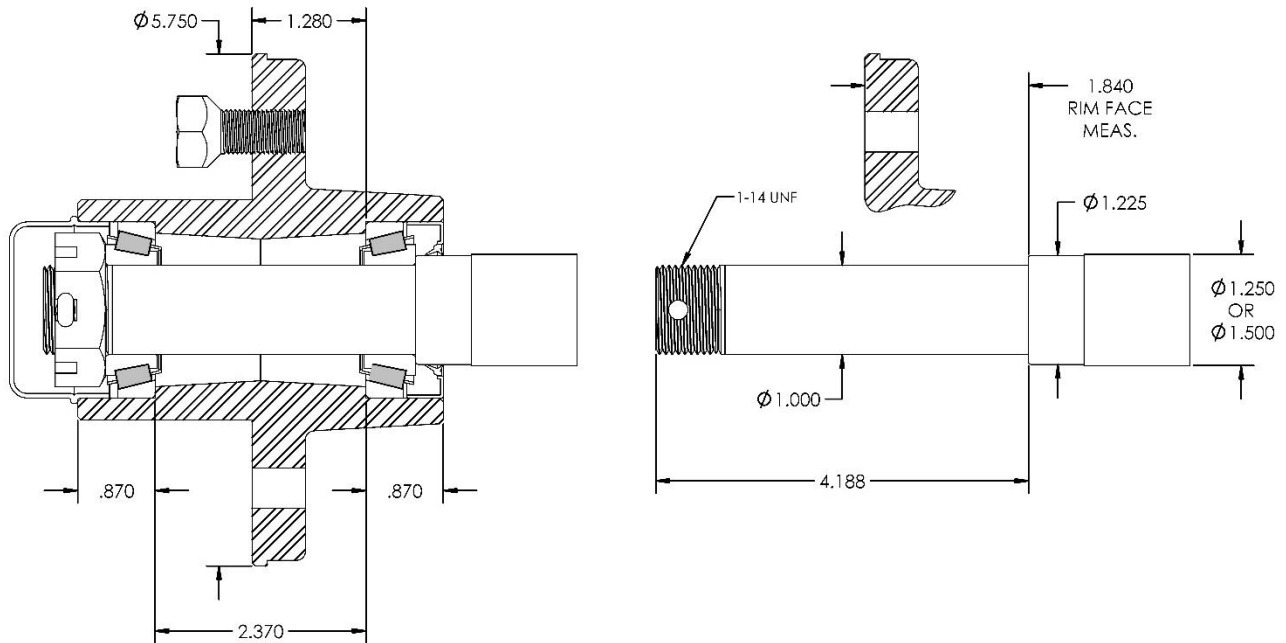

## HUB & COMPONENT PARTS

HUB NO.	INNER CUP	OUTER CUP	INNER		OUTER		DUST CAP	WHEEL BOLT	GREASE SEAL
			CONE	BORE	CONE	BORE			
1000	L44610	L44610	L44643	1.00	L44643	1.00	D1000	F50-20	523696

## SPINDLE & COMPONENT PARTS

SPINDLE NO.	SPINDLE DIAMETER	NUT	WASHER	COTTER PIN	CAPACITY	INTERCHANGES WITH
1000	1.250 or 1.500 CR	SJ114	N/A	316-175	1000 lbs	CTD # HD 211 CTD # HD 213 DEXTER # 8-91 DEXTER # 8-259 RELIABLE # BT 100

HUB CAPACITY BASED ON 0 WHEEL OFFSET.

# # 1100 SERIES

	BOLT CIRCLE	PILOT
4 BOLT	4"	2.500"
5 BOLT	4.500"	2.500"

MAXIMUM WHEEL SIZE 12" DIAMETER

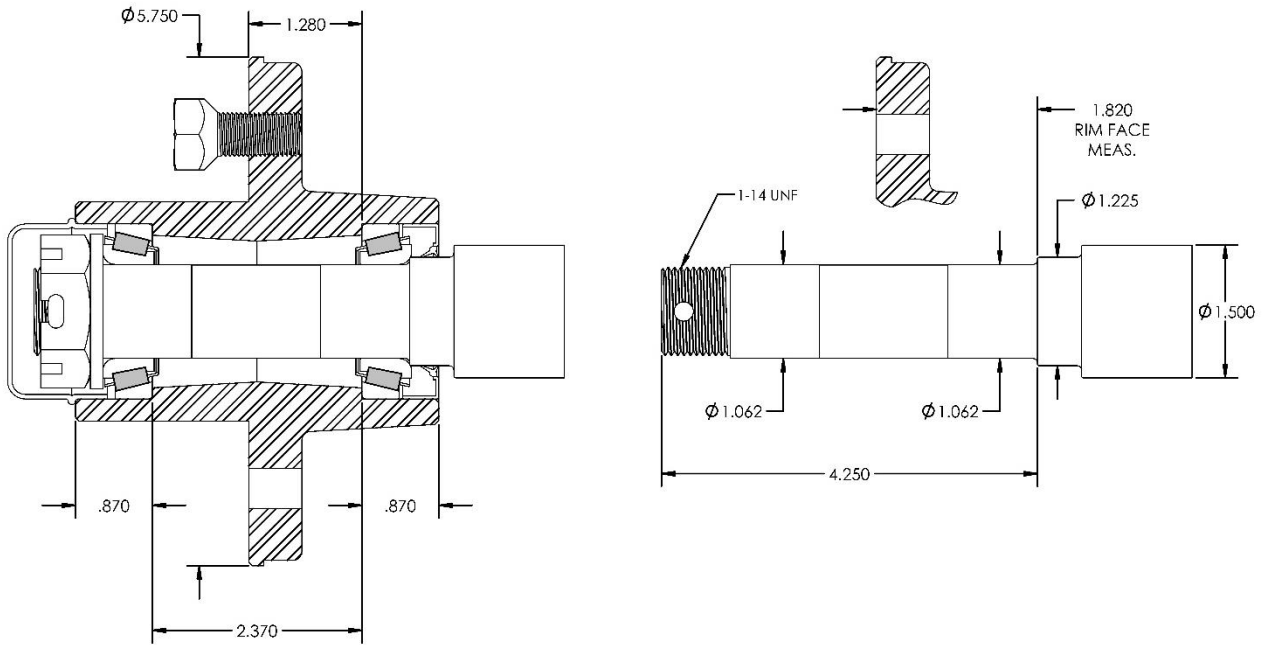

## HUB & COMPONENT PARTS

HUB NO.	INNER CUP	OUTER CUP	INNER		OUTER		DUST CAP	WHEEL BOLT	GREASE SEAL
			CONE	BORE	CONE	BORE			
1100	L44610	L44610	L44649	1.062	L44649	1.062	D1000	F50-20	523696

## SPINDLE & COMPONENT PARTS

SPINDLE NO.	SPINDLE DIAMETER	NUT	WASHER	COTTER PIN	CAPACITY	INTERCHANGES WITH
1000	1.500 CR	SJ114	EM 01000	316-175	1100 lbs	CTD # HD 211-1 CTD # HD 213-1 RELIABLE # BT 150

HUB CAPACITY BASED ON 0 WHEEL OFFSET.



# # 1750 SERIES TRAVEL TRAILER (3500 LB AXLE)

OPTION			BOLT CIRCLE	PILOT
1	1750	5 BOLT	4.500"	2.562"
2	1750	5 BOLT	4.750"	2.562"
3	1750	5 BOLT	5"	2.562"

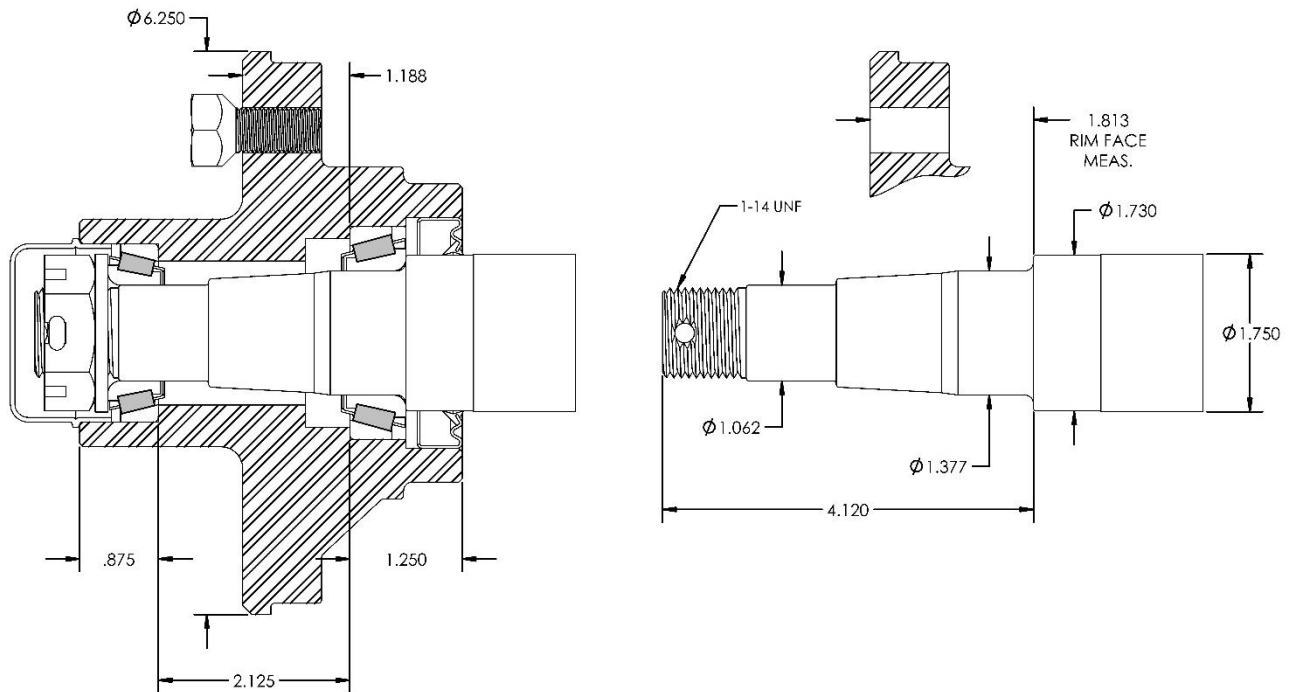

## HUB & COMPONENT PARTS

HUB NO.	INNER CUP	OUTER CUP	INNER		OUTER		DUST CAP	WHEEL BOLT	GREASE SEAL
			CONE	BORE	CONE	BORE			
1750	L68111	L44610	L68149	1.378	L44649	1.062	D1000	F50-20	17406DL

## SPINDLE & COMPONENT PARTS

SPINDLE NO.	SPINDLE DIAMETER	NUT	WASHER	COTTER PIN	CAPACITY	INTERCHANGES WITH
1750	1.750 CR	SJ114	EM 01000	316-175	1750 lbs	RELIABLE # H1000 ARMSTRONG # 055

AVAILABLE WITH PRESS-IN BOLTS.

# # 1250 (411) SERIES

	BOLT CIRCLE	PILOT
4 BOLT	5"	3.625"

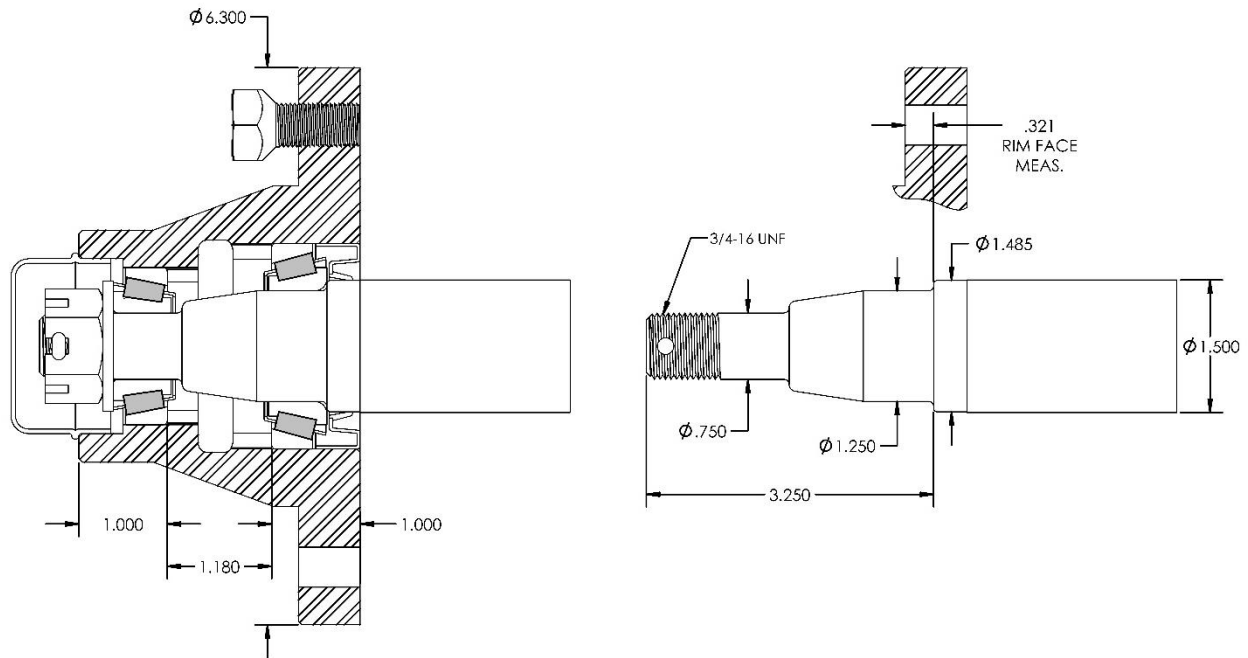

## HUB & COMPONENT PARTS

HUB NO.	INNER CUP	OUTER CUP	INNER		OUTER		DUST CAP	WHEEL BOLT	GREASE SEAL
			CONE	BORE	CONE	BORE			
1250 (411)	LM67010	LM11910	LM67048	1.250	LM11949	.750	D1000	F50-20	14975

## SPINDLE & COMPONENT PARTS

SPINDLE NO.	SPINDLE DIAMETER	NUT	WASHER	COTTER PIN	CAPACITY
1250 (411)	1.500 CR	SF34-16	SAE-3/4	532-150	1250 lbs

HUB CAPACITY BASED ON .250 NEGATIVE-WHEEL OFFSET AT TRACTOR SPEED UP TO 20 MPH.  
AVAILABLE WITH PRESS-IN BOLTS.

# # 1500 SERIES

	BOLT CIRCLE	PILOT
4 BOLT	5"	3.625"

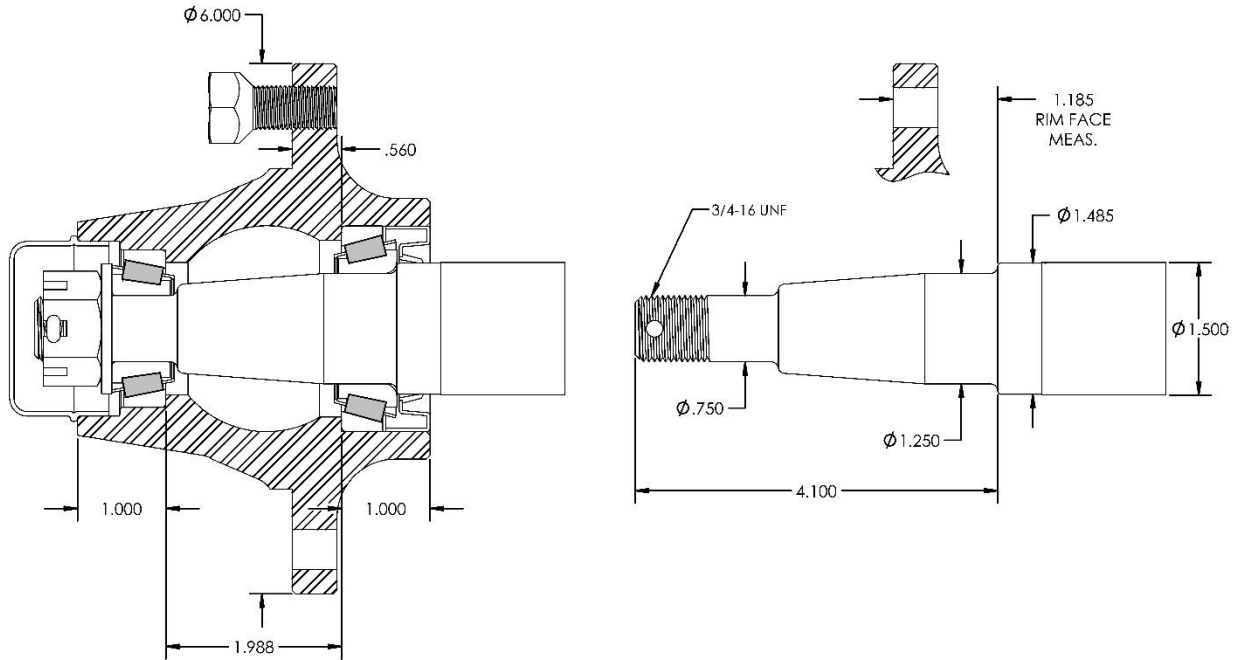

## HUB & COMPONENT PARTS

HUB NO.	INNER CUP	OUTER CUP	INNER		OUTER		DUST CAP	WHEEL BOLT	GREASE SEAL
			CONE	BORE	CONE	BORE			
1500	LM67010	LM11910	LM67048	1.250	LM11949	.750	D1000	F50-20	14975

## SPINDLE & COMPONENT PARTS

SPINDLE NO.	SPINDLE DIAMETER	NUT	WASHER	COTTER PIN	CAPACITY	INTERCHANGES WITH
1500	1.500 CR	SF34-16	SAE-3/4	532-150	1500 lbs	ARMSTRONG #633 EWC #Q-633 WILTON #W-633 RELIABLE #H15-450E CTD #H-413 F&H #107166

HUB CAPACITY BASED ON .250 NEGATIVE-WHEEL OFFSET AT TRACTOR SPEED UP TO 20 MPH.

# # 2400 SERIES

	BOLT CIRCLE	PILOT
4 BOLT	5"	3.625"

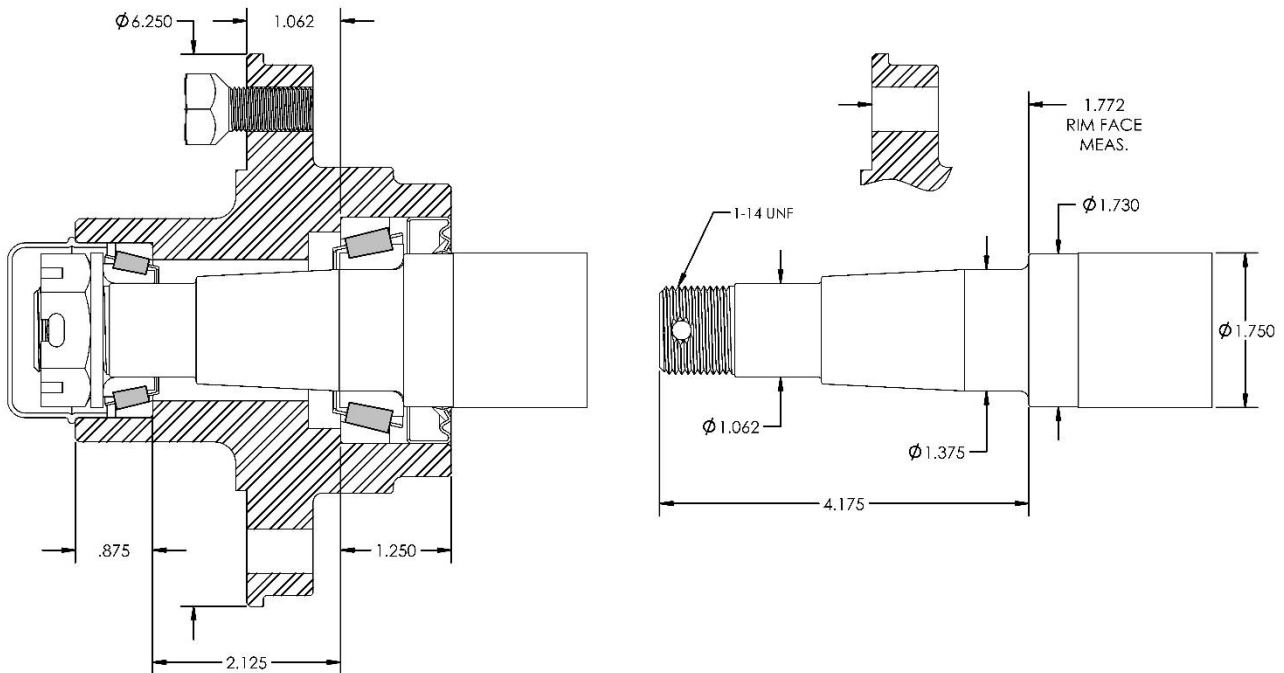

## HUB & COMPONENT PARTS

HUB NO.	INNER CUP	OUTER CUP	INNER		OUTER		DUST CAP	WHEEL BOLT	GREASE SEAL
			CONE	BORE	CONE	BORE			
2400	LM48510	L44610	LM48548	1.375	L44649	1.062	D1000	F50-20	17406DL

## SPINDLE & COMPONENT PARTS

SPINDLE NO.	SPINDLE DIAMETER	NUT	WASHER	COTTER PIN	CAPACITY
2500	1.750 CR	SJ114	EM 01000	316-175	2500 lbs

HUB CAPACITY BASED ON .500 POSITIVE-WHEEL OFFSET AT TRACTOR SPEED UP TO 20 MPH.

# # 2500 SERIES

OPTION			BOLT CIRCLE	PILOT
1	2500	5 BOLT	4.500"	2.562"
2	2500	5 BOLT	4.750"	2.562"
3	2500	5 BOLT	5"	2.562"

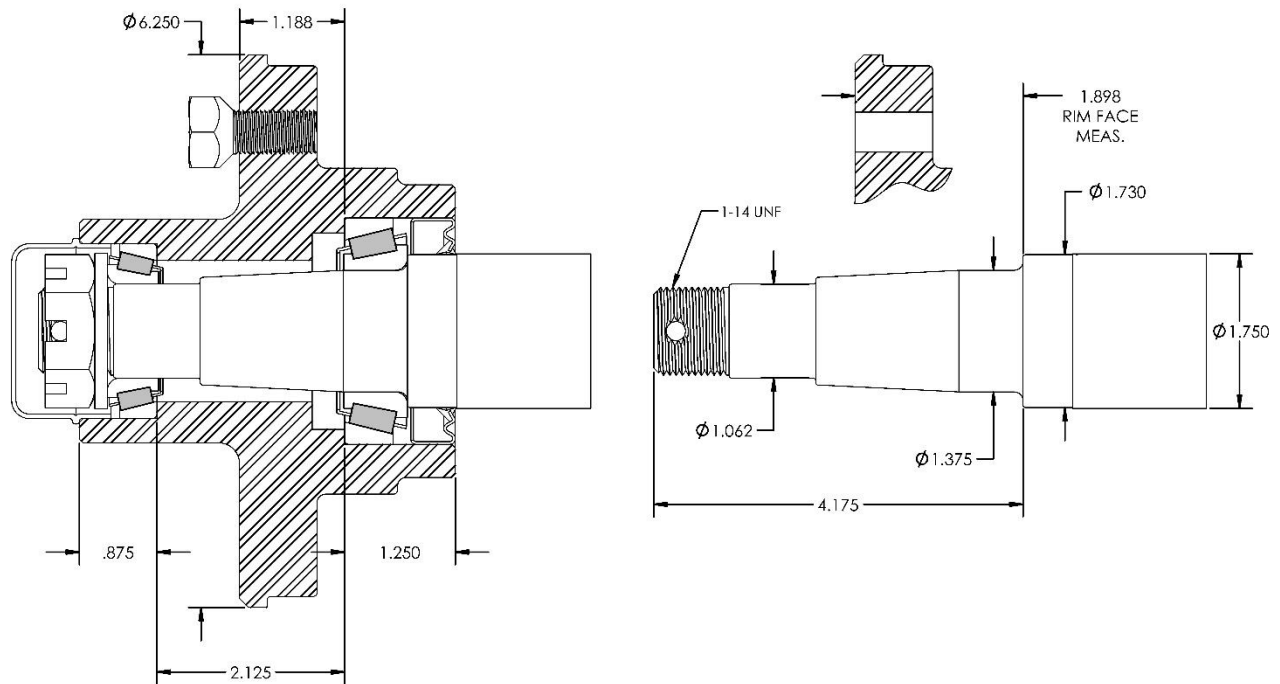

## HUB & COMPONENT PARTS

HUB NO.	INNER CUP	OUTER CUP	INNER		OUTER		DUST CAP	WHEEL BOLT	GREASE SEAL
			CONE	BORE	CONE	BORE			
2500	LM48510	L44610	LM48548	1.375	L44649	1.062	D1000	F50-20	17406DL

## SPINDLE & COMPONENT PARTS

SPINDLE NO.	SPINDLE DIAMETER	NUT	WASHER	COTTER PIN	CAPACITY
2500	1.750 CR	SJ114	EM 01000	316-175	2500 lbs

HUB CAPACITY BASED ON .500 POSITIVE-WHEEL OFFSET AT TRACTOR SPEED UP TO 20 MPH.

# # 1800 SERIES

	BOLT CIRCLE	PILOT
5 BOLT	5.500"	4"

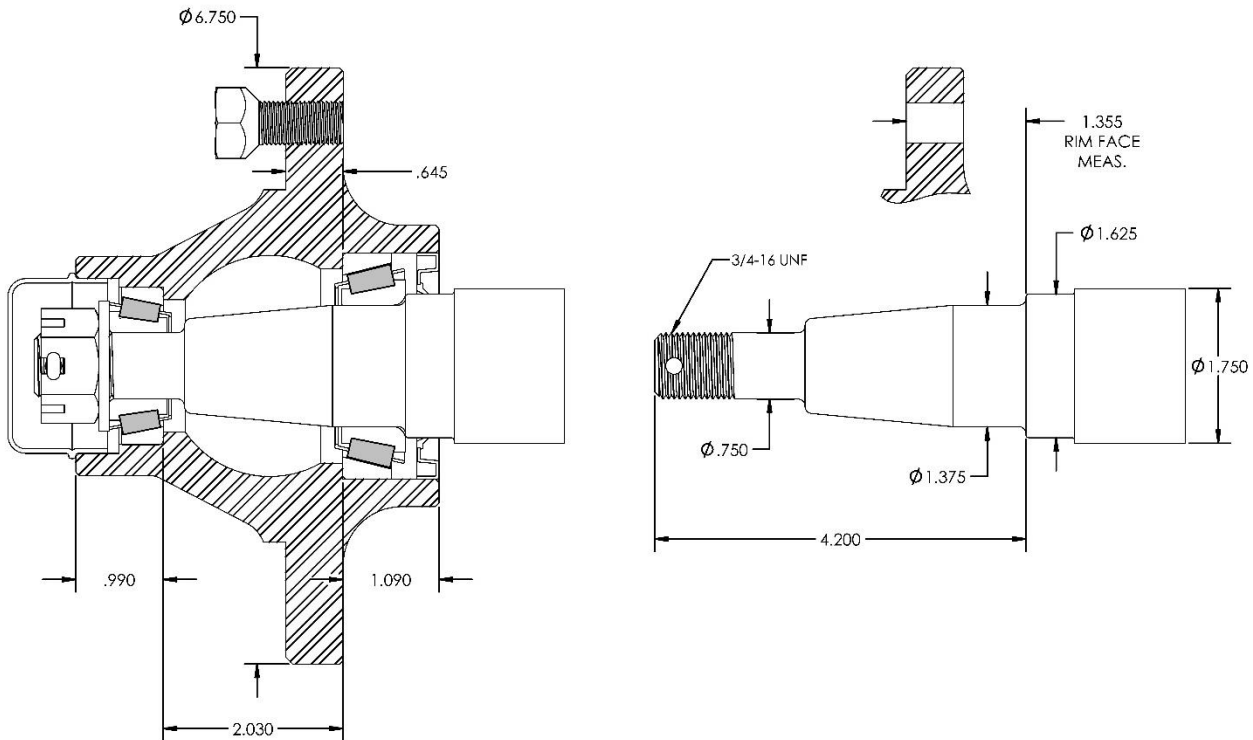

## HUB & COMPONENT PARTS

HUB NO.	INNER CUP	OUTER CUP	INNER		OUTER		DUST CAP	WHEEL BOLT	GREASE SEAL
			CONE	BORE	CONE	BORE			
1800	LM48510	LM11910	LM48548	1.375	LM11949	.750	D1000	F50-20	16284

## SPINDLE & COMPONENT PARTS

SPINDLE NO.	SPINDLE DIAMETER	NUT	WASHER	COTTER PIN	CAPACITY	INTERCHANGES WITH
1800	1.750 CR	SF34-16	SAE-3/4	532-150	1800 lbs	CTD #H-516

HUB CAPACITY BASED ON .250 NEGATIVE WHEEL OFFSET AT TRACTOR SPEED UP TO 20 MPH.

# # 3000 SERIES

	BOLT CIRCLE	PILOT
5 BOLT	5.500"	4"

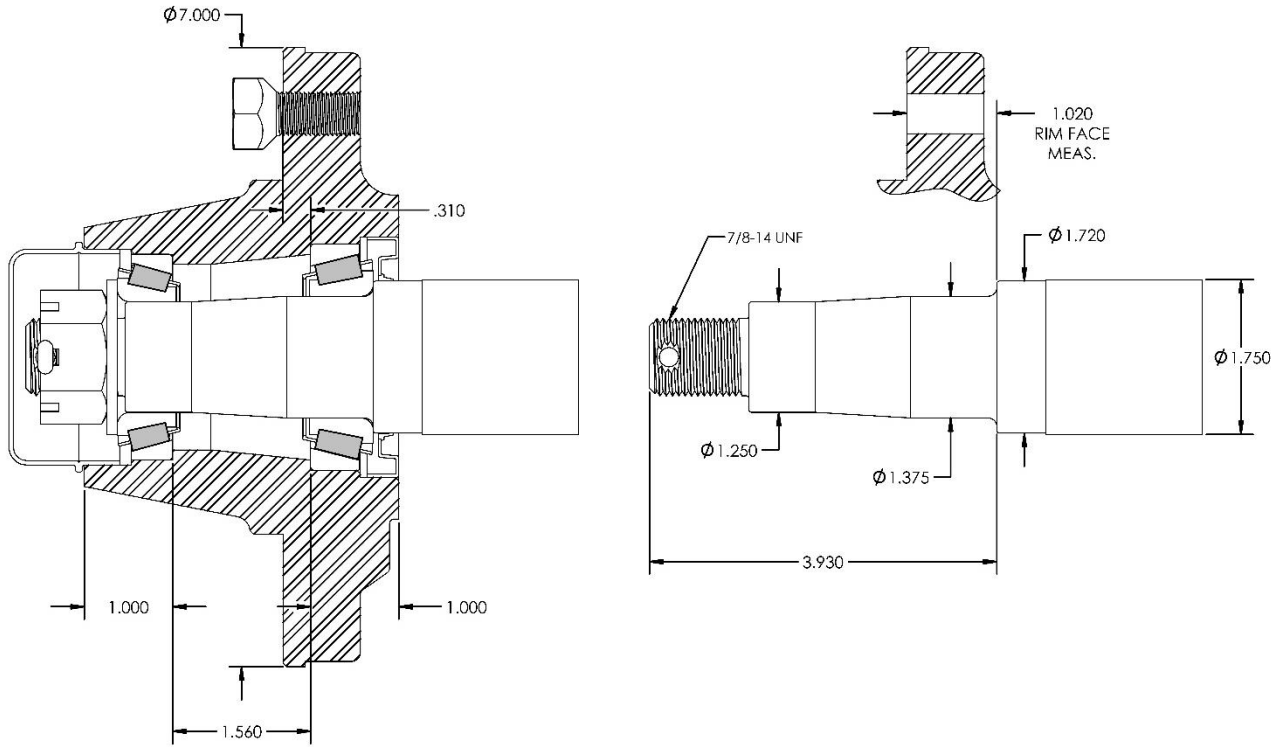

## HUB & COMPONENT PARTS

HUB NO.	INNER CUP	OUTER CUP	INNER		OUTER		DUST CAP	WHEEL BOLT	GREASE SEAL
			CONE	BORE	CONE	BORE			
3000	LM48510	LM67010	LM48548	1.375	LM67048	1.250	D3000	F50-20	17617

## SPINDLE & COMPONENT PARTS

SPINDLE NO.	SPINDLE DIAMETER	NUT	WASHER	COTTER PIN	CAPACITY	INTERCHANGES WITH
3000	1.750 CR	SF78-14	SAE-7/8	316-175	3000 lbs	ARMSTRONG #255 EWC #Q-719 WILTON #W-25-5 RELIABLE #H25-555 CTD #H-517 F&H #104682

HUB CAPACITY BASED ON .250 NEGATIVE WHEEL OFFSET AT TRACTOR SPEED UP TO 20 MPH.

# # 4500 SERIES

	BOLT CIRCLE	PILOT
5 BOLT	5.500"	4"

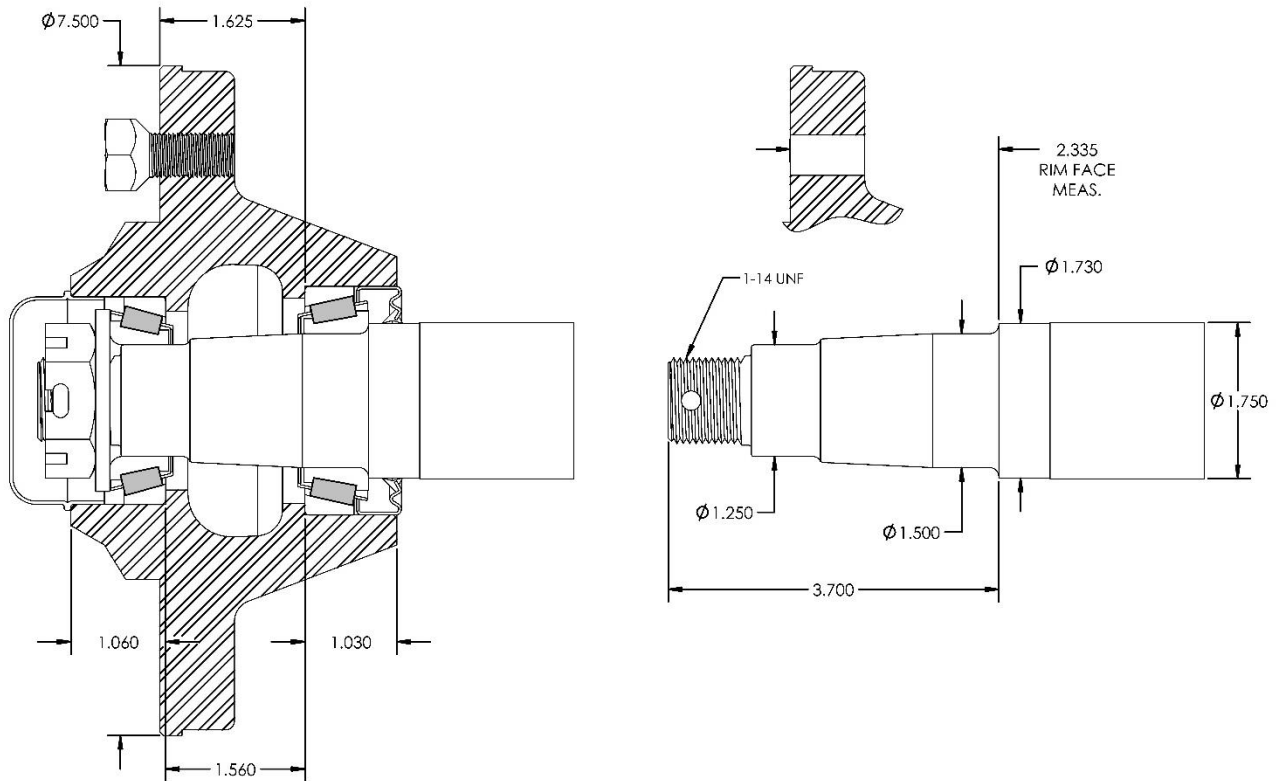

## HUB & COMPONENT PARTS

HUB NO.	INNER CUP	OUTER CUP	INNER		OUTER		DUST CAP	WHEEL BOLT	GREASE SEAL
			CONE	BORE	CONE	BORE			
4500	LM29710	LM67010	LM29749	1.500	LM67048	1.250	D4000	F50-20	17406DL

## SPINDLE & COMPONENT PARTS

SPINDLE NO.	SPINDLE DIAMETER	NUT	WASHER	COTTER PIN	CAPACITY
4000	1.750 CR	SJ114	SAE 1000H	316-175	4000 lbs

HUB CAPACITY BASED ON .250 NEGATIVE WHEEL OFFSET AT TRACTOR SPEED UP TO 20 MPH.



# # 2800 SERIES

	BOLT CIRCLE	PILOT
6 BOLT	6"	4.625"

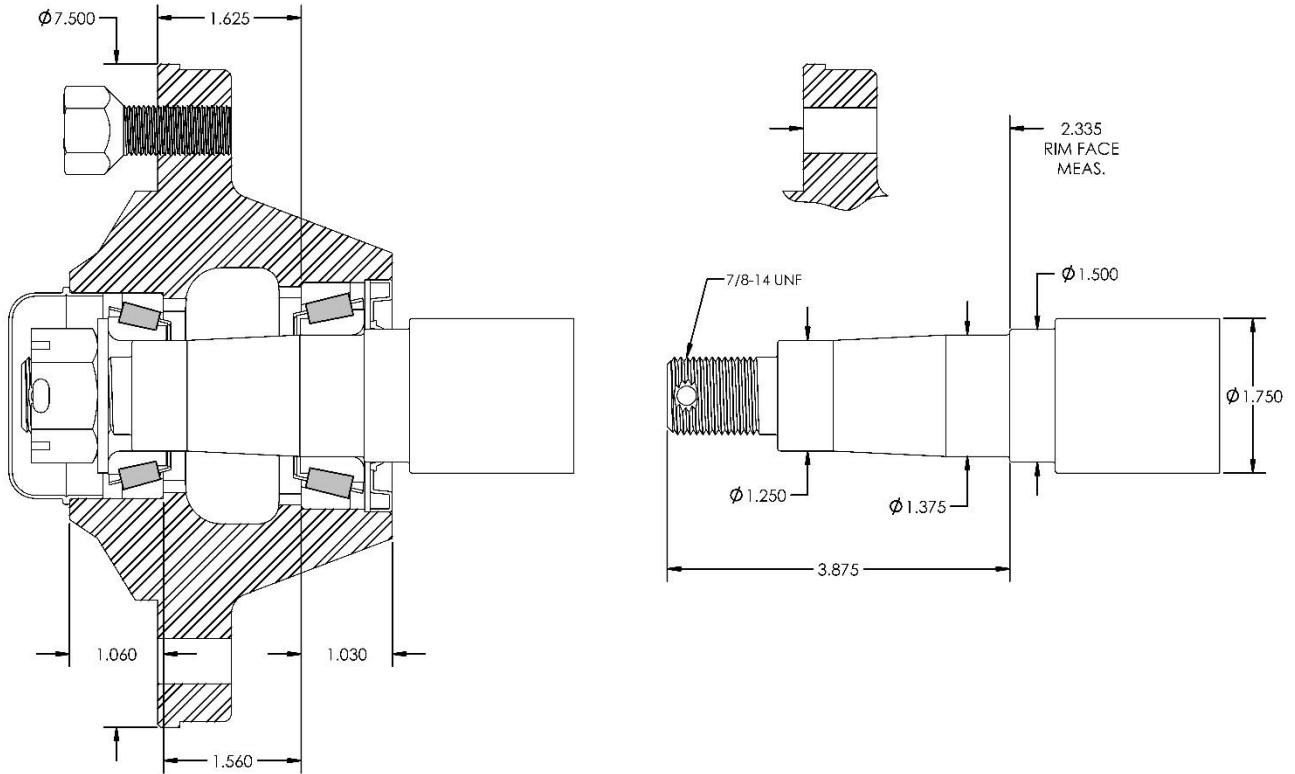

## HUB & COMPONENT PARTS

HUB NO.	INNER CUP	OUTER CUP	INNER		OUTER		DUST CAP	WHEEL BOLT	GREASE SEAL
			CONE	BORE	CONE	BORE			
2800	LM48510	LM67010	LM48548	1.375	LM67048	1.250	D4000	F916-18	15190

## SPINDLE & COMPONENT PARTS

SPINDLE NO.	SPINDLE DIAMETER	NUT	WASHER	COTTER PIN	CAPACITY	INTERCHANGES WITH
2800	1.750 CR	SF78-14	SAE-7/8	316-175	2800 lbs	ARMSTRONG #709 EWC #Q-709 WILTON #W-709 CTD #H-611-2

HUB CAPACITY BASED ON 1.125 POSITIVE WHEEL OFFSET AT TRACTOR SPEED UP TO 20 MPH.

# # 4000 SERIES

	BOLT CIRCLE	PILOT
6 BOLT	6"	4.625"

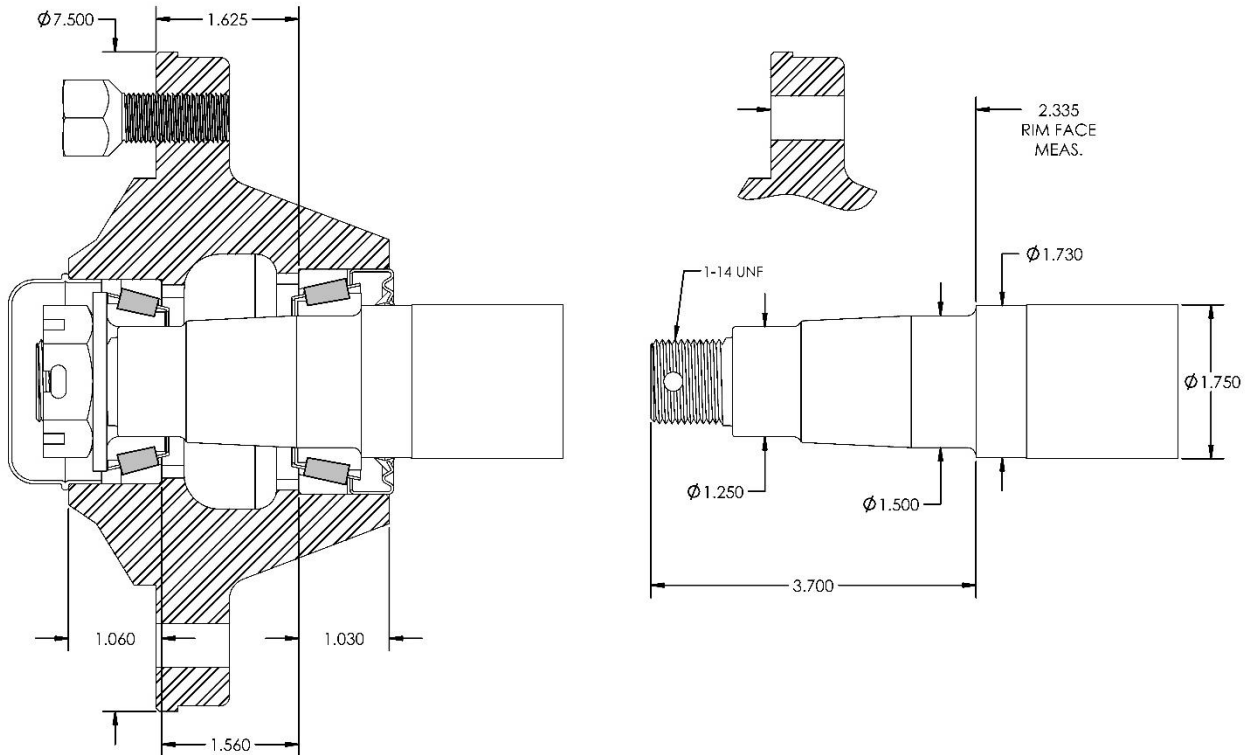

## HUB & COMPONENT PARTS

HUB NO.	INNER CUP	OUTER CUP	INNER		OUTER		DUST CAP	WHEEL BOLT	GREASE SEAL
			CONE	BORE	CONE	BORE			
4000	LM29710	LM67010	LM29749	1.500	LM67048	1.250	D4000	F916-18	17406DL

## SPINDLE & COMPONENT PARTS

SPINDLE NO.	SPINDLE DIAMETER	NUT	WASHER	COTTER PIN	CAPACITY	INTERCHANGES WITH
4000	1.750 CR	SJ114	SAE 1000H	316-175	4000 lbs	ARMSTRONG #777 EWC #Q-777 CTD #H-611-1

HUB CAPACITY BASED ON 1.125 POSITIVE WHEEL OFFSET AT TRACTOR SPEED UP TO 20 MPH.

# # 5000 SERIES

	BOLT CIRCLE	PILOT
6 BOLT	6"	4.625"

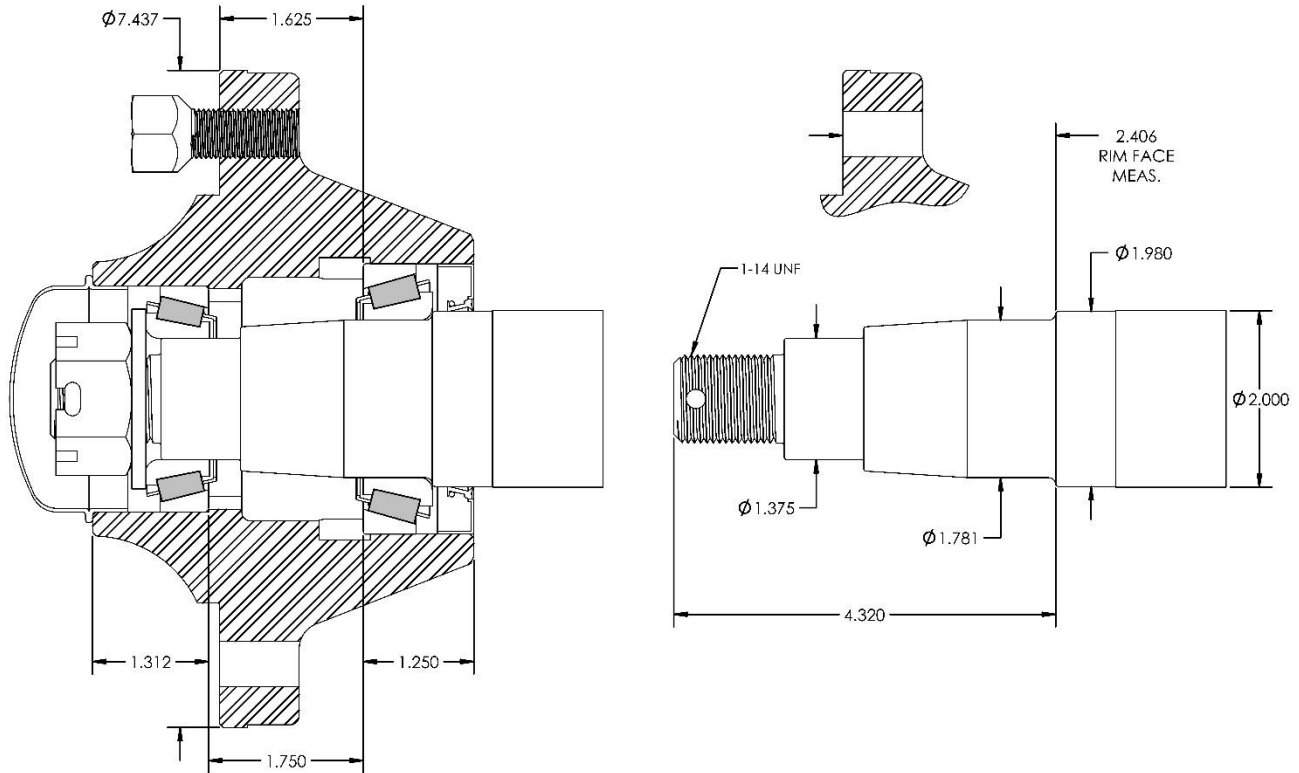

## HUB & COMPONENT PARTS

HUB NO.	INNER CUP	OUTER CUP	INNER		OUTER		DUST CAP	WHEEL BOLT	GREASE SEAL
			CONE	BORE	CONE	BORE			
5000	LM603011	LM48510	LM603049	1.781	LM48548	1.375	D5000	F916-18	20044

## SPINDLE & COMPONENT PARTS

SPINDLE NO.	SPINDLE DIAMETER	NUT	WASHER	COTTER PIN	CAPACITY	INTERCHANGES WITH
5000	2.000 CR	SF114	SAE 1000H	316-175	5000 lbs	ARMSTRONG #614 CTD #H-614

HUB CAPACITY BASED ON 1.125 POSITIVE WHEEL OFFSET AT TRACTOR SPEED UP TO 20 MPH.

# # 5000B SERIES

		BOLT CIRCLE	PILOT
<b>FRONT</b>	6 BOLT	6"	4.625"
<b>BACK</b>	6 BOLT	5.500"	4.375"

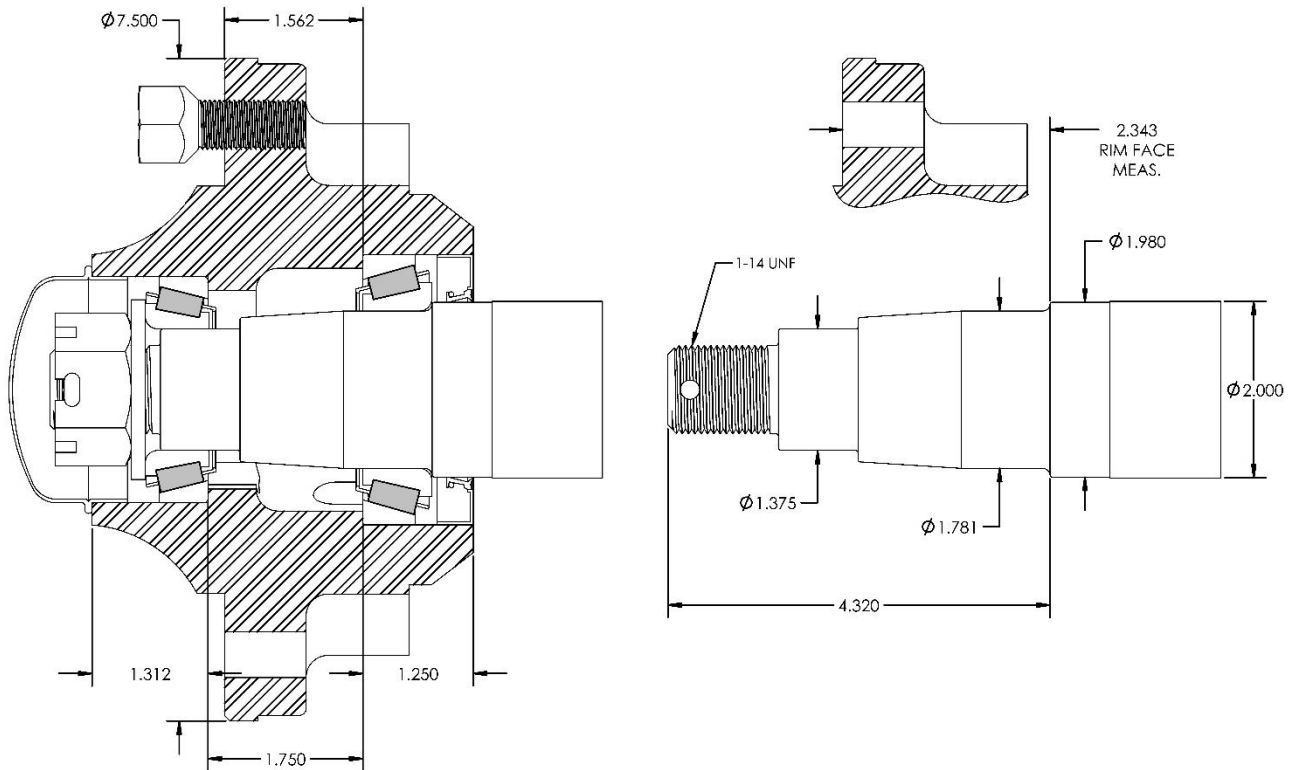

## HUB & COMPONENT PARTS

HUB NO.	INNER CUP	OUTER CUP	INNER		OUTER		DUST CAP	WHEEL BOLT	GREASE SEAL
			CONE	BORE	CONE	BORE			
5000-B	LM603011	LM48510	LM603049	1.781	LM48548	1.375	D5000	F916-18	20044

## SPINDLE & COMPONENT PARTS

SPINDLE NO.	SPINDLE DIAMETER	NUT	WASHER	COTTER PIN	CAPACITY
5000	2.000 CR	SF114	SAE 1000H	316-175	5000 lbs

HUB CAPACITY BASED ON 1.125 POSITIVE WHEEL OFFSET AT TRACTOR SPEED UP TO 20 MPH.

# # 6000 SERIES

	BOLT CIRCLE	PILOT
6 BOLT	6"	4.625"

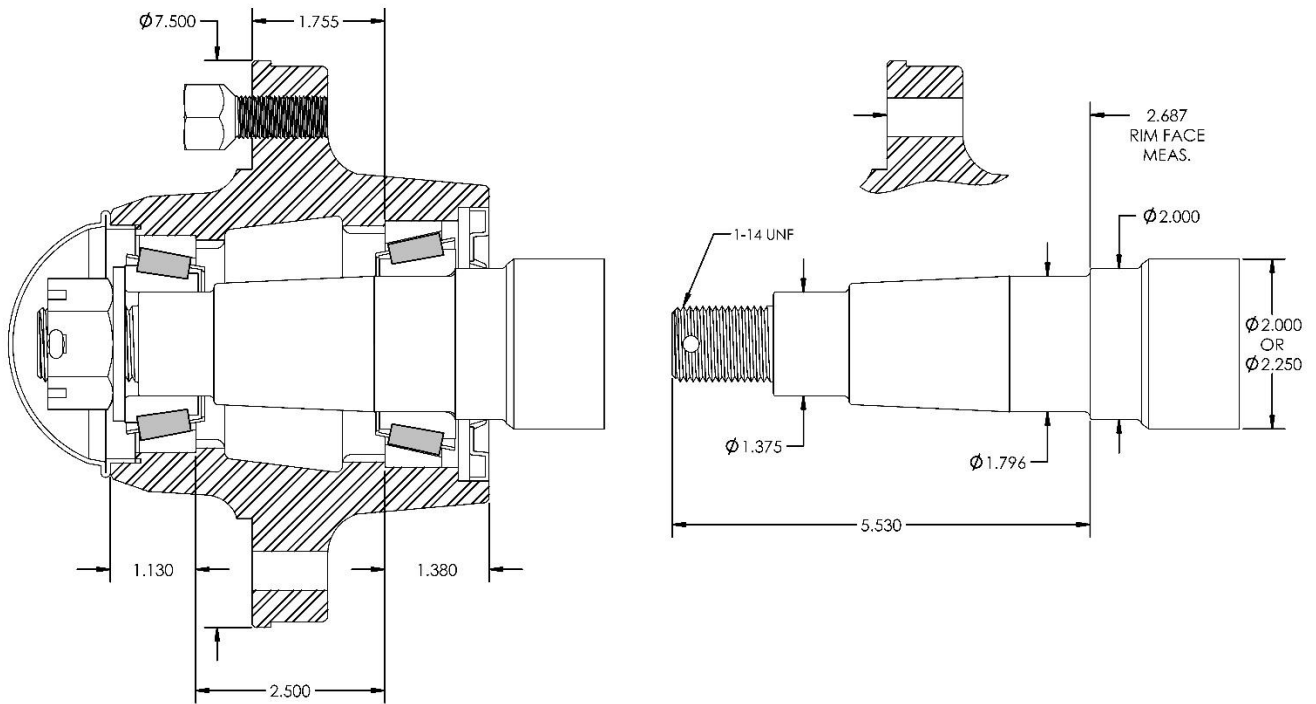

## HUB & COMPONENT PARTS

HUB NO.	INNER CUP	OUTER CUP	INNER		OUTER		DUST CAP	WHEEL BOLT	GREASE SEAL
			CONE	BORE	CONE	BORE			
6000	25520	25821	25590	1.796	25877	1.375	D6000	F916-18	20148

## SPINDLE & COMPONENT PARTS

SPINDLE NO.	SPINDLE DIAMETER	NUT	WASHER	COTTER PIN	CAPACITY	INTERCHANGES WITH
6000	2.000 or 2.250 CR	SF114	SAE 1000H	316-175	6000 lbs	ARMSTRONG #803 EWC #Q-803 WILTON #803-530 CTD #H-633

HUB CAPACITY BASED ON 1.125 POSITIVE WHEEL OFFSET AT TRACTOR SPEED UP TO 20 MPH.

# # 5000-8 SERIES

	BOLT CIRCLE	PILOT
8 BOLT	6.500"	4.750"

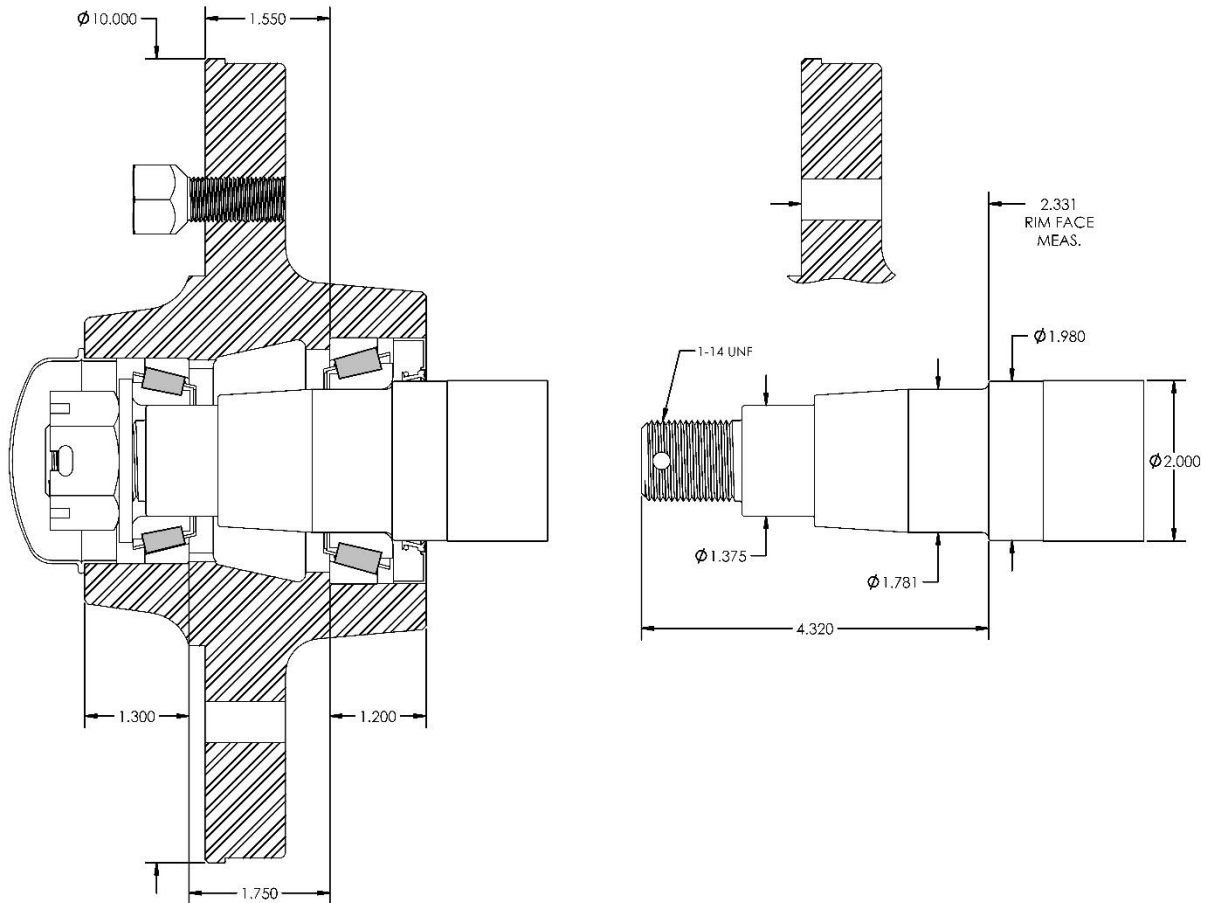

## HUB & COMPONENT PARTS

HUB NO.	INNER CUP	OUTER CUP	INNER		OUTER		DUST CAP	WHEEL BOLT	GREASE SEAL
			CONE	BORE	CONE	BORE			
5000-8	LM603011	LM48510	LM603049	1.781	LM48548	1.375	D5000	F58-18	20044

## SPINDLE & COMPONENT PARTS

SPINDLE NO.	SPINDLE DIAMETER	NUT	WASHER	COTTER PIN	CAPACITY
5000	2.000 CR	SF114	SAE 1000H	316-175	5000 lbs

HUB CAPACITY BASED ON 1.125 POSITIVE WHEEL OFFSET AT TRACTOR SPEED UP TO 20 MPH.

# # 5500 SERIES

	BOLT CIRCLE	PILOT
8 BOLT	8"	6"

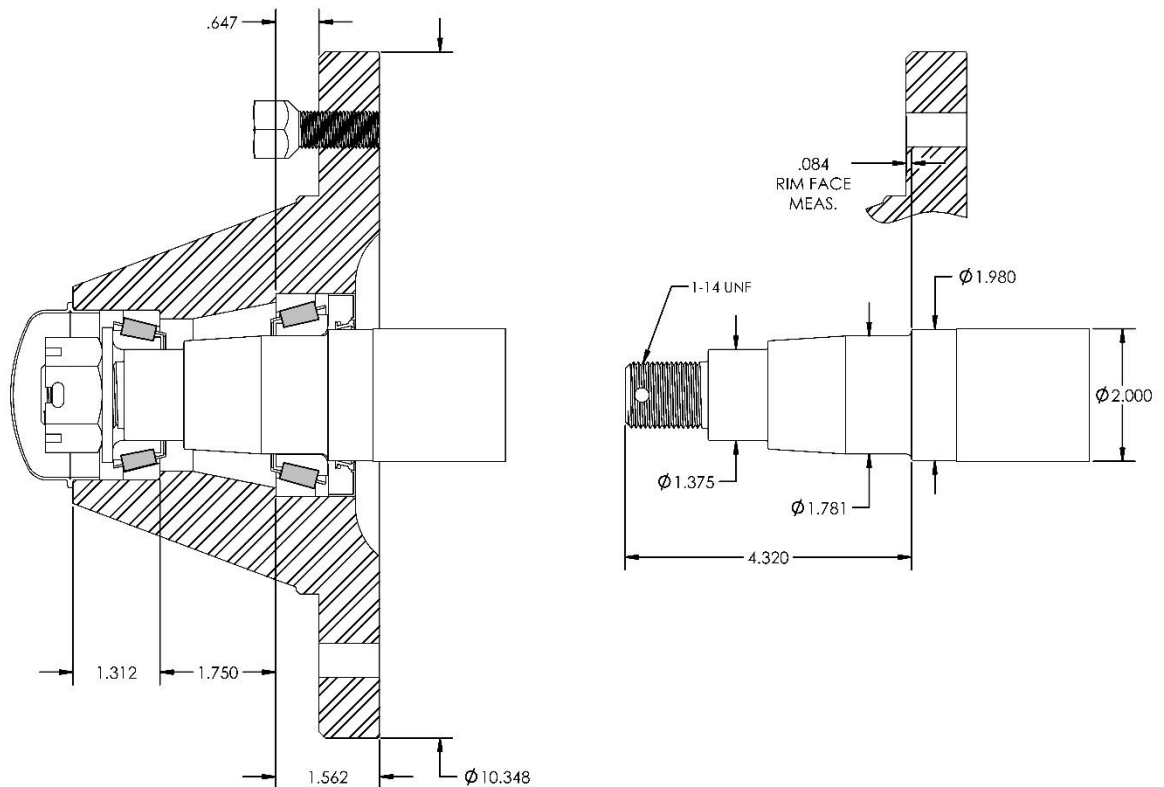

## HUB & COMPONENT PARTS

HUB NO.	INNER CUP	OUTER CUP	INNER		OUTER		DUST CAP	WHEEL BOLT	GREASE SEAL
			CONE	BORE	CONE	BORE			
5500	LM603011	LM48510	LM603049	1.781	LM48548	1.375	D5000	F916-18	20044

## SPINDLE & COMPONENT PARTS

SPINDLE NO.	SPINDLE DIAMETER	NUT	WASHER	COTTER PIN	CAPACITY
5000	2.000 CR	SF114	SAE 1000H	316-175	5000 lbs

HUB CAPACITY BASED ON 1.500 NEGATIVE WHEEL OFFSET AT TRACTOR SPEED UP TO 20 MPH.

# # 6500 SERIES

	BOLT CIRCLE	PILOT
8 BOLT	8"	6"

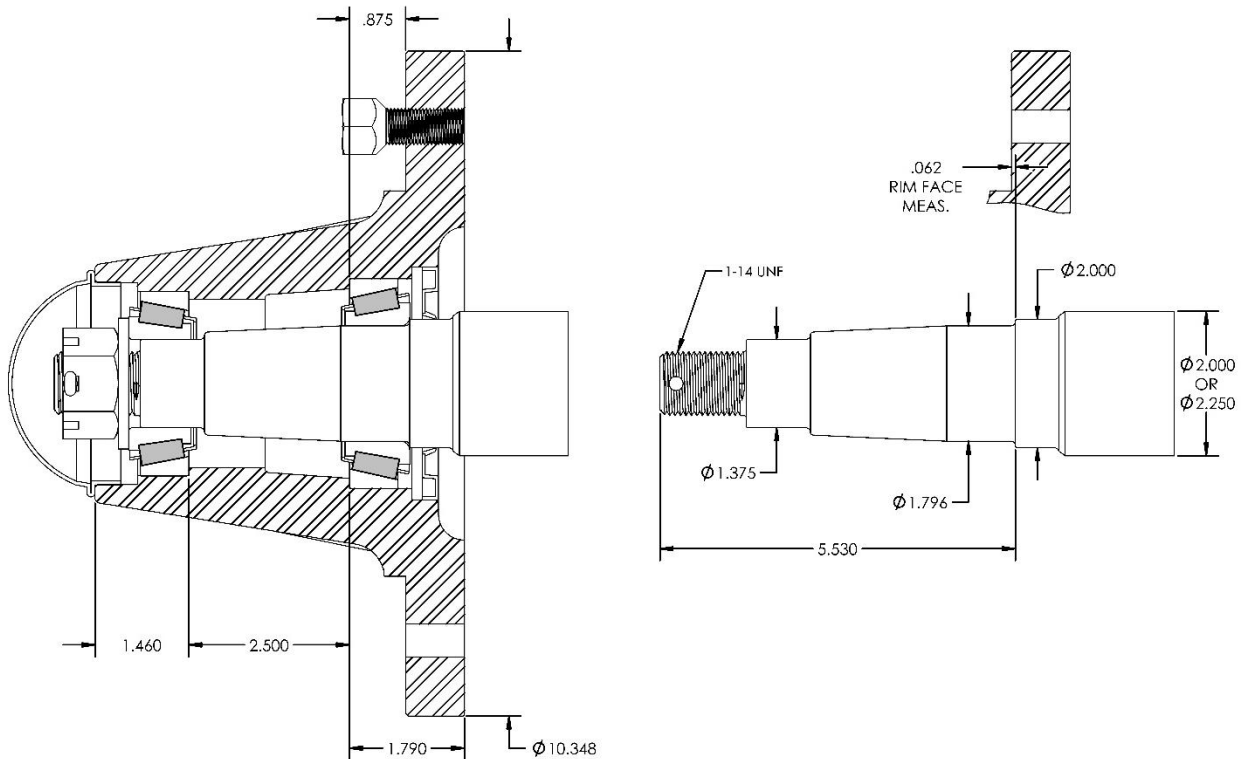

## HUB & COMPONENT PARTS

HUB NO.	INNER CUP	OUTER CUP	INNER		OUTER		DUST CAP	WHEEL BOLT	GREASE SEAL
			CONE	BORE	CONE	BORE			
6500	25520	25821	25590	1.796	25877	1.375	D6000	F916-18	20148

## SPINDLE & COMPONENT PARTS

SPINDLE NO.	SPINDLE DIAMETER	NUT	WASHER	COTTER PIN	CAPACITY	INTERCHANGES WITH
6000	2.000 or 2.250 CR	SF114	SAE 1000H	316-175	6000 lbs	ARMSTRONG #778 EWC #Q-778 WILTON #778-600 CTD #H-811-1 F&H #107230

HUB CAPACITY BASED ON 1.500 NEGATIVE WHEEL OFFSET AT TRACTOR SPEED UP TO 20 MPH.



# # 8000 SERIES

## for BRAKE APPLICATION

		BOLT CIRCLE	PILOT
FRONT	8 BOLT	8"	6"
BACK	8 BOLT	5.500"	4.375"

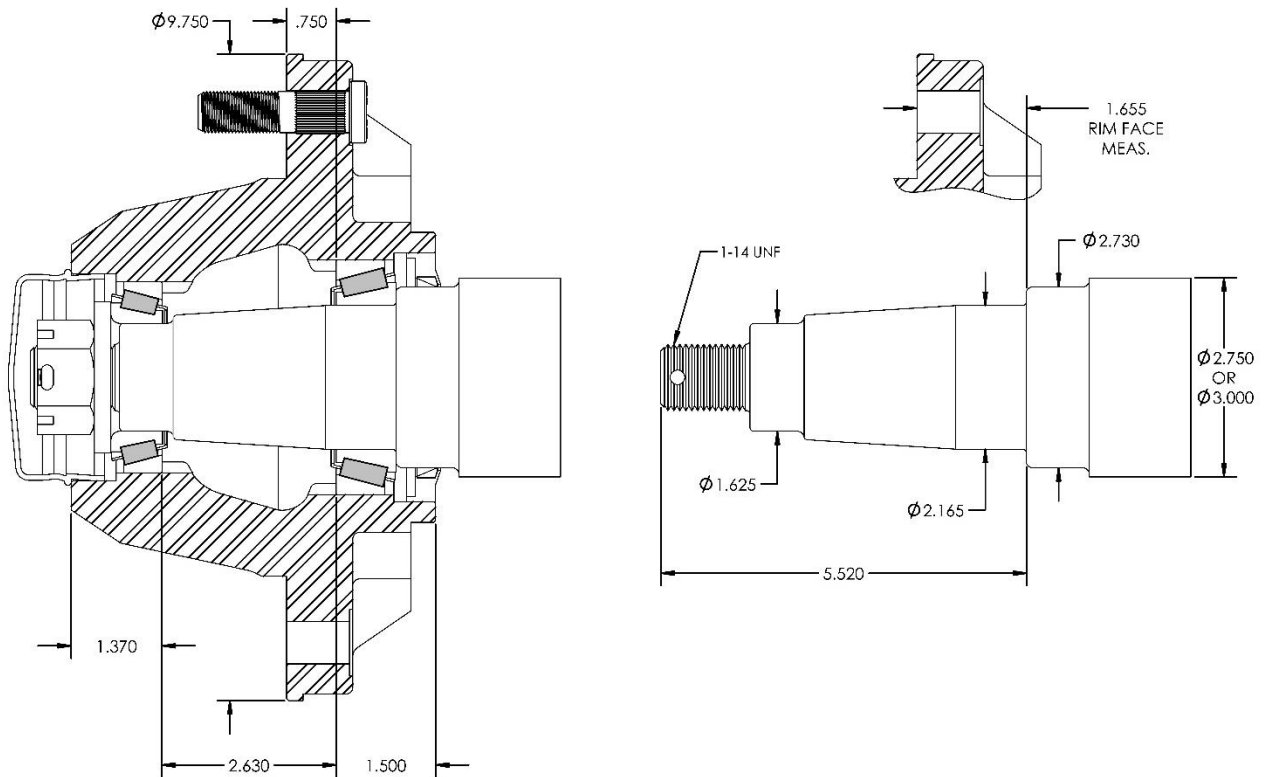

### HUB & COMPONENT PARTS

HUB NO.	INNER CUP	OUTER CUP	INNER		OUTER		DUST CAP	WHEEL BOLT	GREASE SEAL
			CONE	BORE	CONE	BORE			
8000	JLM506810	LM501310	JLM506849	2.165	LM501349	1.625	D8000	5/8" PIB	27361

### SPINDLE & COMPONENT PARTS

SPINDLE NO.	SPINDLE DIAMETER	NUT	WASHER	COTTER PIN	CAPACITY	INTERCHANGES WITH
8000	2.750 or 3.000 HR, SP	SF114	EM 08000	316-175	8000 lbs	ARMSTRONG #608 F&H #107013

HUB CAPACITY BASED ON 1.500 NEGATIVE WHEEL OFFSET AT TRACTOR SPEED UP TO 20 MPH.

# # 10000 SERIES

for BRAKE APPLICATION

		BOLT CIRCLE	PILOT
FRONT	8 BOLT	8"	6"
BACK	8 BOLT	5.500"	4.375"

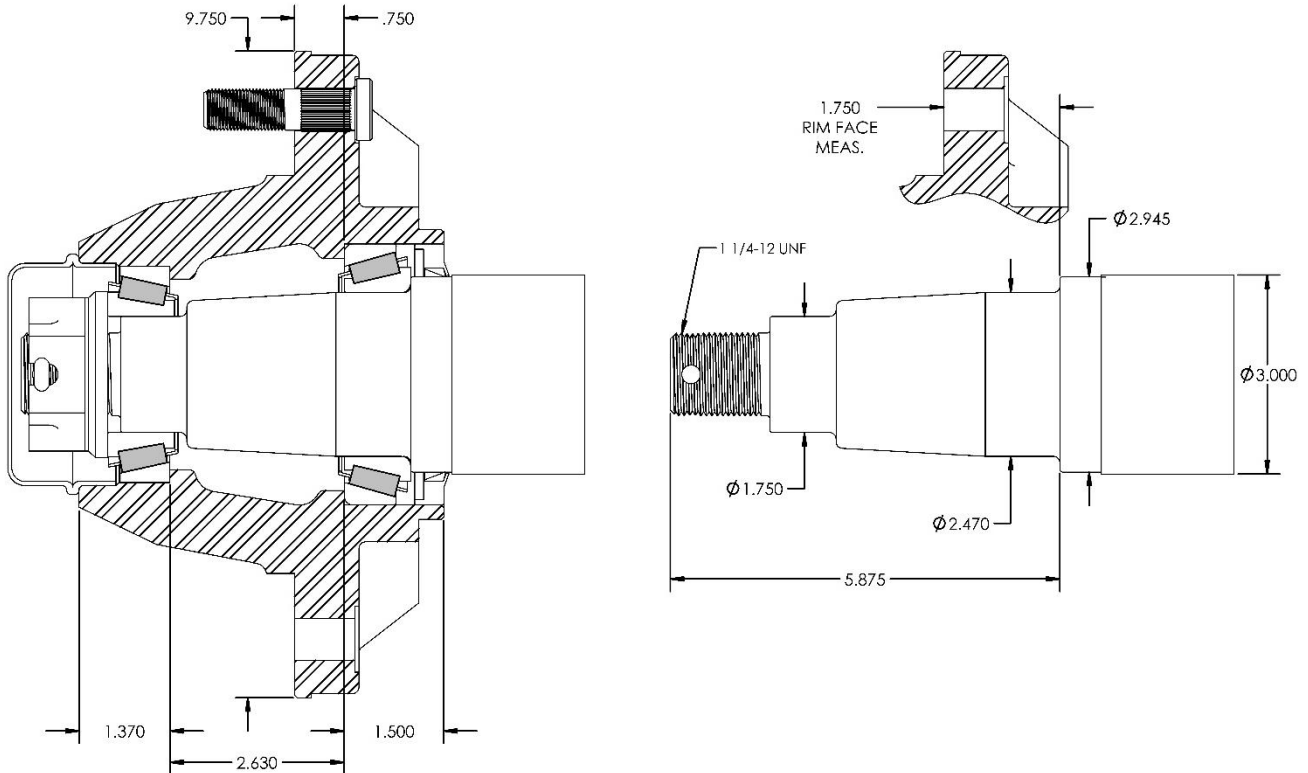

## HUB & COMPONENT PARTS

HUB NO.	INNER CUP	OUTER CUP	INNER		OUTER		DUST CAP	WHEEL BOLT	GREASE SEAL
			CONE	BORE	CONE	BORE			
10,000	28921	25520	28995	2.470	25581	1.750	D10000	5/8" PIB	29273

## SPINDLE & COMPONENT PARTS

SPINDLE NO.	SPINDLE DIAMETER	DUCTILE FLANGE NUT	COTTER PIN	CAPACITY
10,000	3.000 SP	SF12512	416-250	10,000 lbs

HUB CAPACITY BASED ON 1.500 NEGATIVE WHEEL OFFSET AT TRACTOR SPEED UP TO 20 MPH.

# # 12000 SERIES for BRAKE APPLICATION

		BOLT CIRCLE	PILOT
FRONT	8 BOLT	8"	6"
BACK	8 BOLT	5.500"	4.375"

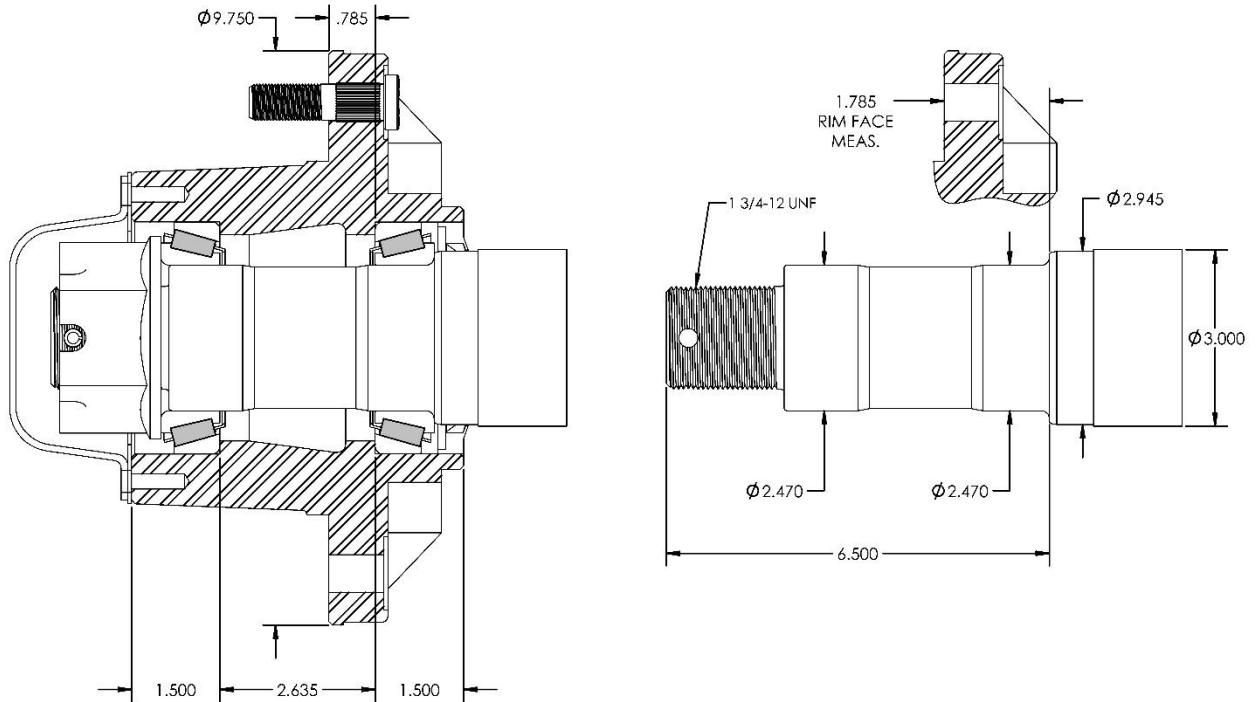

## HUB & COMPONENT PARTS

HUB NO.	INNER CUP	OUTER CUP	INNER		OUTER		DUST CAP	WHEEL BOLT	GREASE SEAL
			CONE	BORE	CONE	BORE			
12,000	28921	28921	28995	2.470	28995	2.470	D12000 GASKET	5/8" PIB	29273

## SPINDLE & COMPONENT PARTS

SPINDLE NO.	SPINDLE DIAMETER	DUCTILE FLANGE NUT	ROLL PIN	CAPACITY
12,000	3.000 SP	SF17512	516 275	12,000 lbs

HUB CAPACITY BASED ON 1.500 NEGATIVE WHEEL OFFSET AT TRACTOR SPEED UP TO 20 MPH.

# # 871 (12000) SERIES

## for BRAKE APPLICATION

		BOLT CIRCLE	PILOT
FRONT	10 BOLT	11.250"	8.665"
BACK	6 BOLT	8.250"	6"

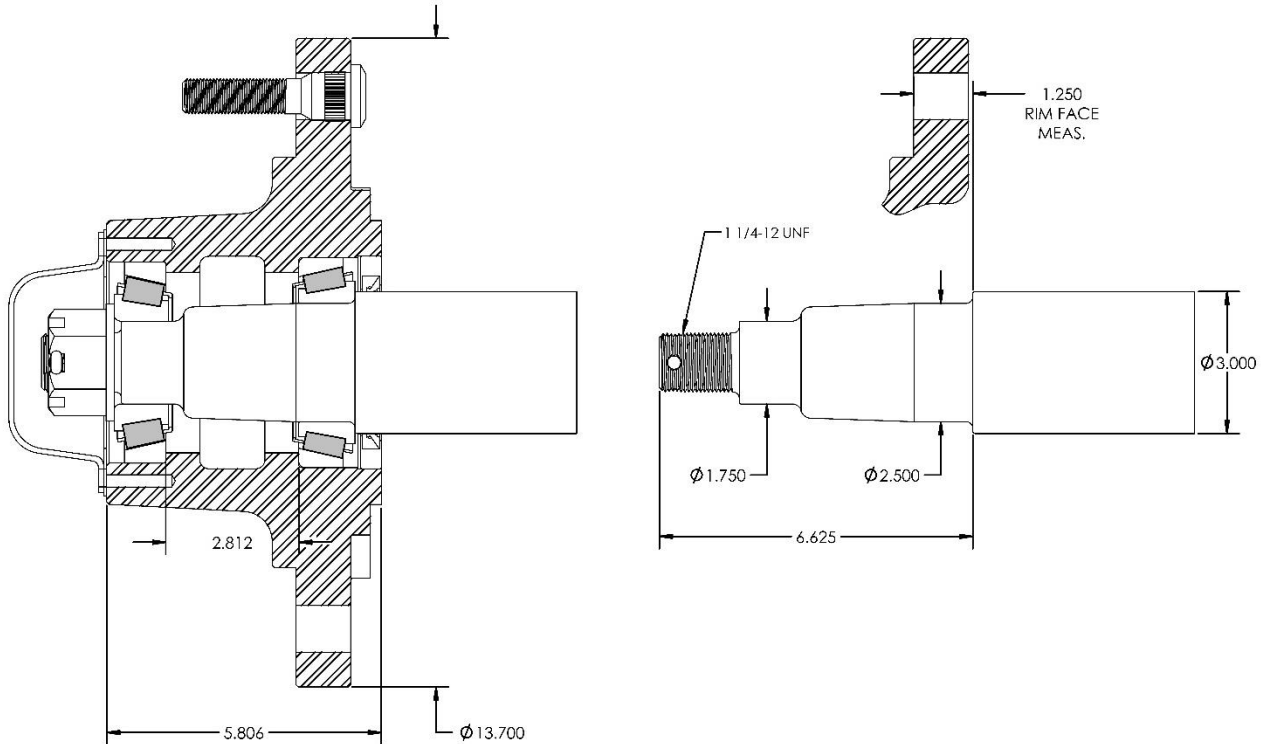

### HUB & COMPONENT PARTS

HUB NO.	INNER CUP	OUTER CUP	INNER		OUTER		DUST CAP	WHEEL BOLT	GREASE SEAL
			CONE	BORE	CONE	BORE			
871	39520	453A	39585	2.500	460	1.750	D871	3/4" PIB	30087

### SPINDLE & COMPONENT PARTS

SPINDLE NO.	SPINDLE DIAMETER	NUT	WASHER	COTTER PIN	CAPACITY
871	3.000 SP	SF12512 (2H)	EM10000	732-2	12,000 lbs

HUB CAPACITY BASED ON WHEEL OFFSET AT TRACTOR SPEED UP TO 20 MPH.

# # 873 (15000) SERIES

## for BRAKE APPLICATION

		BOLT CIRCLE	PILOT
<b>FRONT</b>	10 BOLT	11.250"	8.665"
<b>BACK</b>	6 BOLT	8.250"	6"

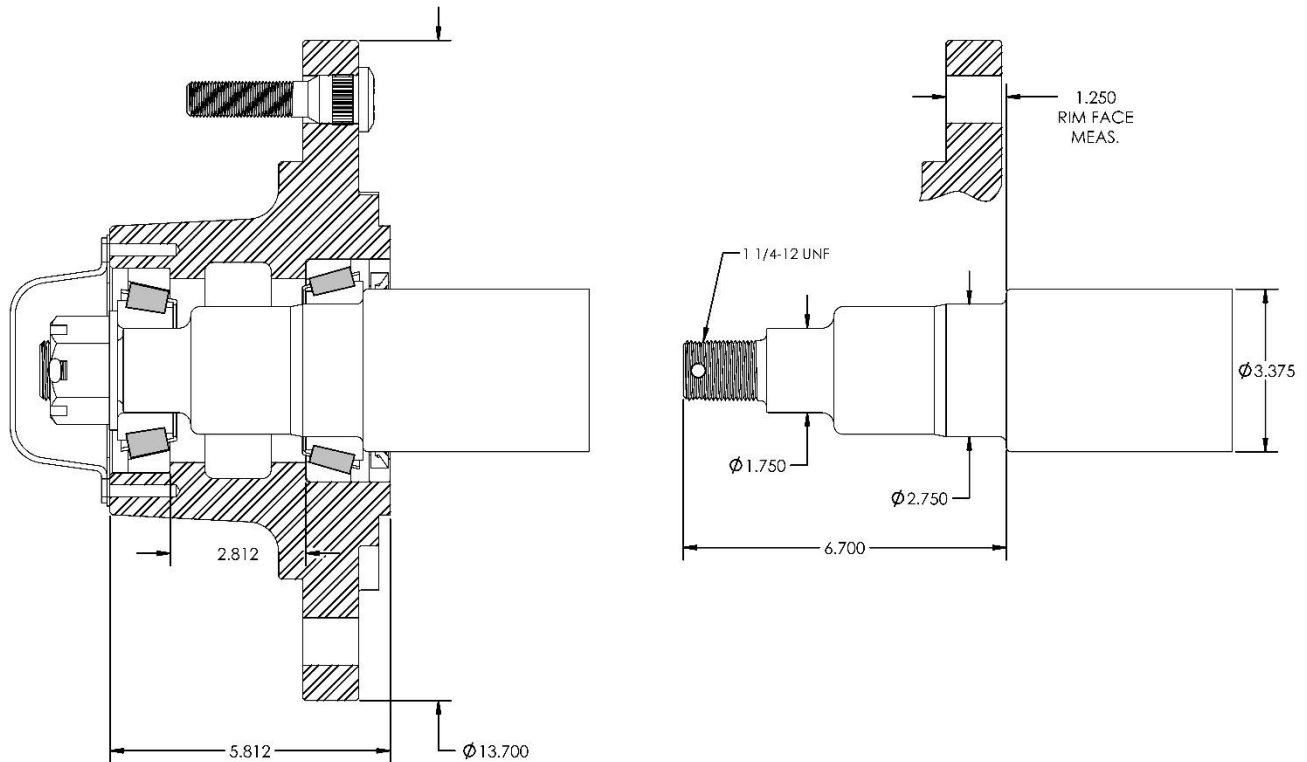

### HUB & COMPONENT PARTS

HUB NO.	INNER CUP	OUTER CUP	INNER		OUTER		DUST CAP	WHEEL BOLT	GREASE SEAL
			CONE	BORE	CONE	BORE			
873	33462	453A	33275	2.750	460	1.750	D873	3/4" PIB	33772

### SPINDLE & COMPONENT PARTS

SPINDLE NO.	SPINDLE DIAMETER	NUT	WASHER	COTTER PIN	CAPACITY
873	3.375 SP	SF12512 (2H)	EM10000	416-250	15,000 lbs

HUB CAPACITY BASED ON 0 WHEEL OFFSET AT TRACTOR SPEED UP TO 20 MPH.

# # 16000 SERIES

for BRAKE APPLICATION with OILBATH OPTION

		BOLT CIRCLE	PILOT
FRONT	10 BOLT	11.250"	8.625"
BACK	9 BOLT	8.250"	6"

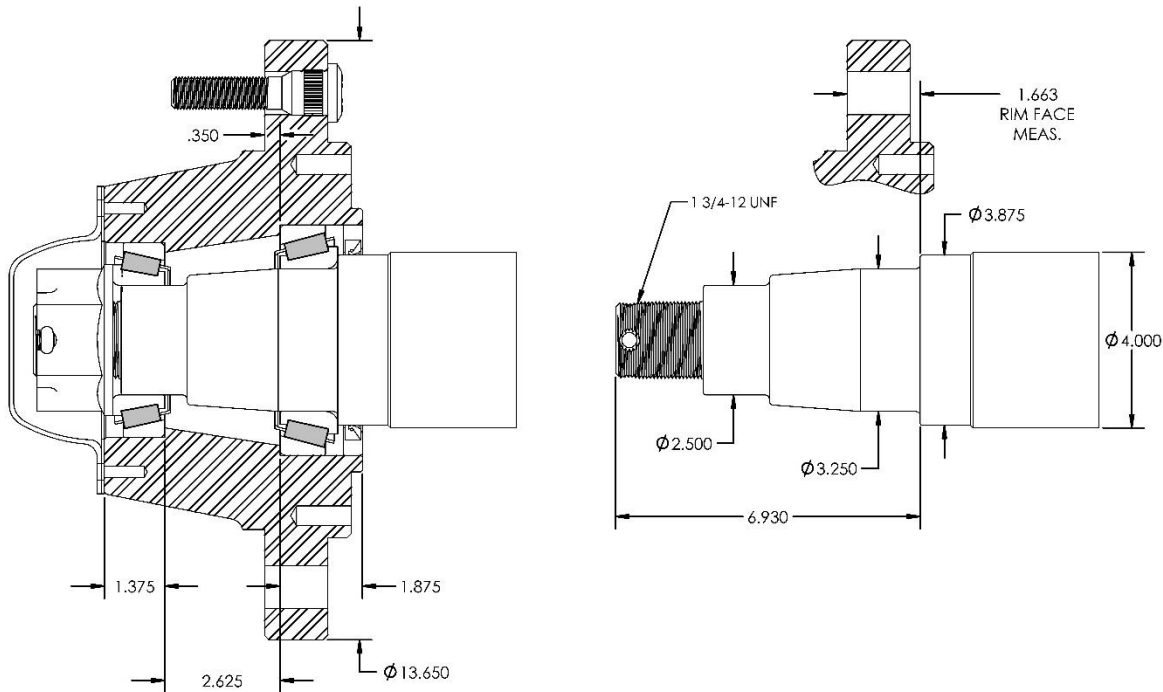

## HUB & COMPONENT PARTS

HUB NO.	INNER CUP	OUTER CUP	INNER		OUTER		DUST CAP	WHEEL BOLT	GREASE SEAL
			CONE	BORE	CONE	BORE			
16,000	47620	39520	47687	3.250	39585	2.500	D16000 GASKET	3/4" PIB or 22 mm PIB	38730

## SPINDLE & COMPONENT PARTS

SPINDLE NO.	SPINDLE DIAMETER	DUCTILE FLANGE NUT	COTTER PIN	CAPACITY	INTERCHANGES WITH
16,000	4.000 HR, CR, SP	SF17512	516-350	18,000 lbs	900

HUB CAPACITY BASED ON 1.500 POSITIVE WHEEL OFFSET AT TRACTOR SPEED UP TO 20 MPH.  
WEIGHT RATING BASED ON APPLICATION.

# # 16000 HD SERIES

for BRAKE APPLICATION with OILBATH OPTION

		BOLT CIRCLE	PILOT
FRONT	10 BOLT	11.250"	8.625"
BACK	9 BOLT	8.250"	6"

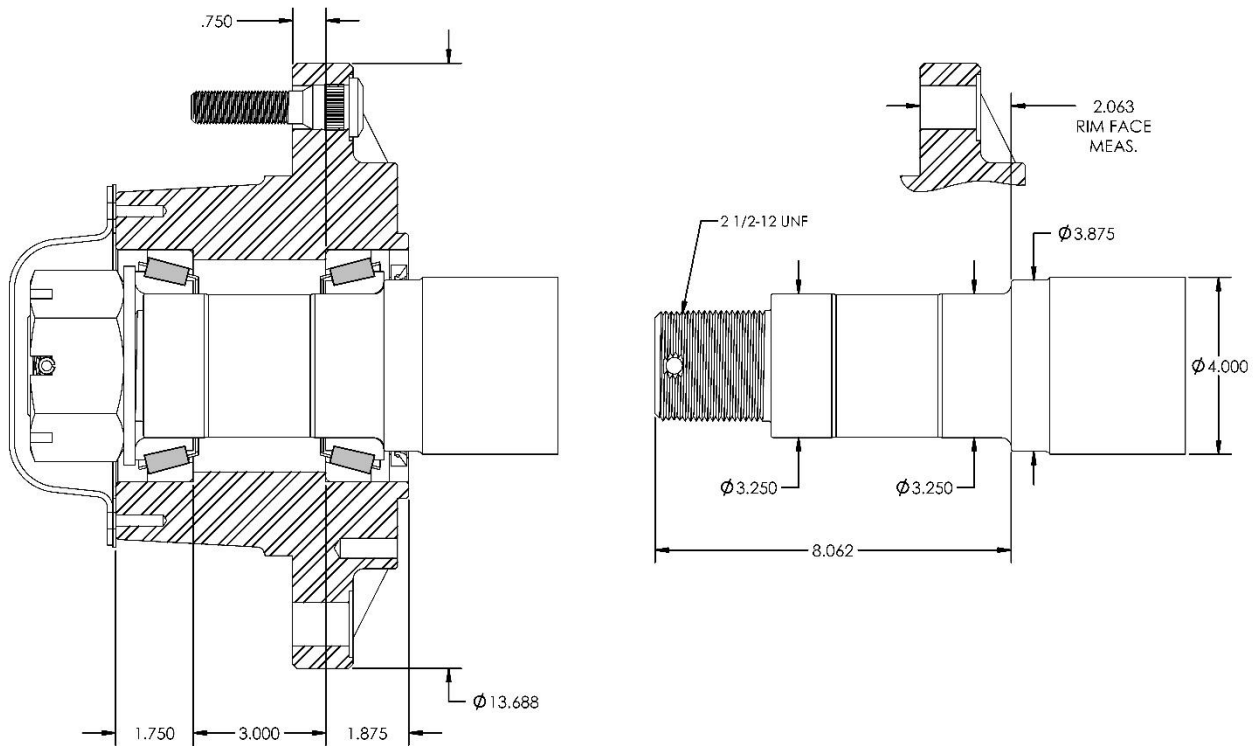

## HUB & COMPONENT PARTS

HUB NO.	INNER CUP	OUTER CUP	INNER		OUTER		DUST CAP	WHEEL BOLT	GREASE SEAL
			CONE	BORE	CONE	BORE			
EM16,000HD	47620	47620	47687	3.250	47687	3.250	D25000 GASKET	3/4" PIB or 22 mm PIB	38730

## SPINDLE & COMPONENT PARTS

SPINDLE NO.	SPINDLE DIAMETER	NUT	WASHER	ROLL PIN	CAPACITY
EM16,000HD	4.000 SP	SF2512	EM25M	3754	20,000 lbs

HUB CAPACITY BASED ON 1.500 POSITIVE WHEEL OFFSET AT TRACTOR SPEED UP TO 20 MPH.  
WEIGHT RATING BASED ON APPLICATION.

# # 20000 SERIES

for **IDLER** or **BRAKE APPLICATION**

		<b>BOLT CIRCLE</b>	<b>PILOT</b>
<b>FRONT</b>	10 BOLT	13.188"	11.040"
<b>BACK</b>	10 BOLT	9.5"	7"

## IDLER AS SHOWN

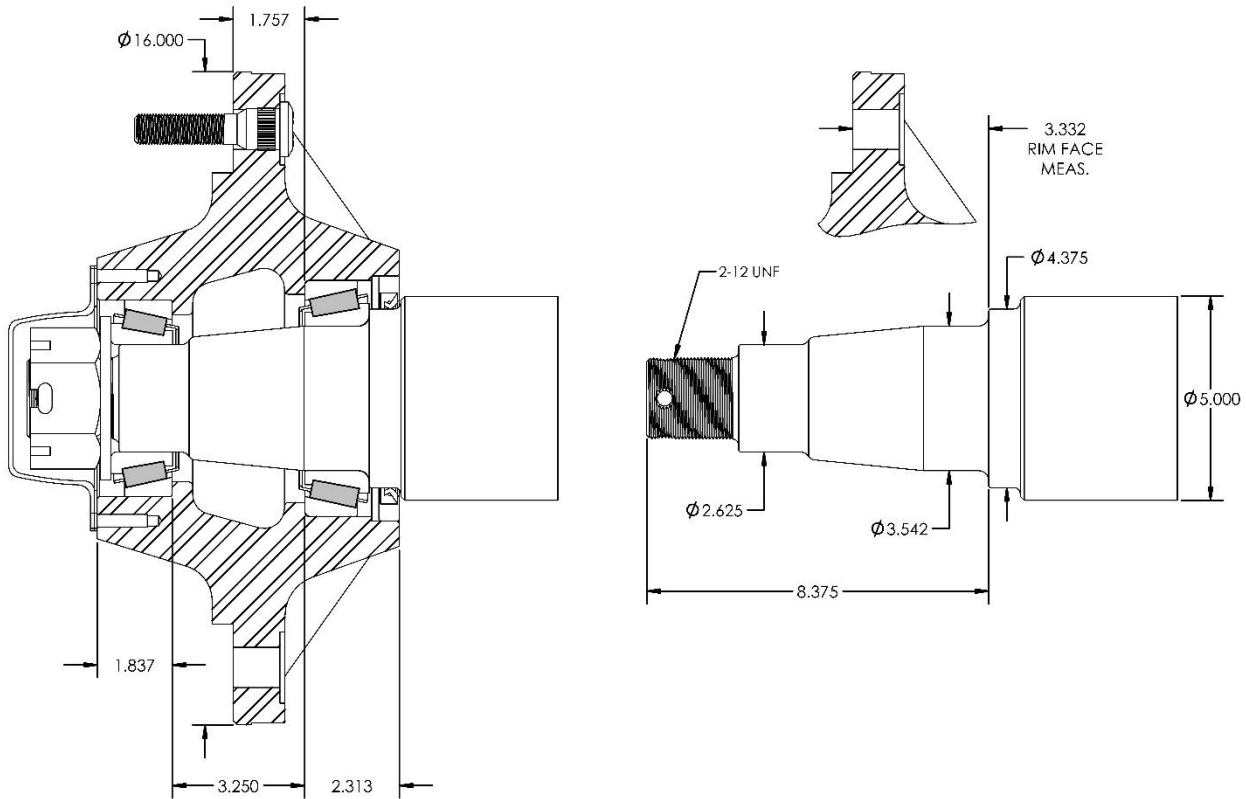

## HUB & COMPONENT PARTS

HUB NO.	INNER CUP	OUTER CUP	INNER		OUTER		DUST CAP	WHEEL BOLT	GREASE SEAL
			CONE	BORE	CONE	BORE			
<b>20,000</b>	HM 218210	HM 212010	HM 218248	3.542	HM 212049	2.625	D20000 GASKET	3/4" PIB or 22 mm PIB	43771

## SPINDLE & COMPONENT PARTS

SPINDLE NO.	SPINDLE DIAMETER	NUT	WASHER	ROLL PIN	CAPACITY	INTERCHANGES WITH
<b>20,000</b>	5.000 4140	SF212	EM20M	3753	<b>IDLER</b> 22,500 lbs <b>BRAKE</b> 25,000 lbs	WILTON #W-881 CTD #H-1020 HDA1021

**HUB CAPACITY BASED ON 1.500 POSITIVE WHEEL OFFSET AT TRACTOR SPEED UP TO 20 MPH. WEIGHT RATING BASED ON APPLICATION.**



# # 891 SERIES

for IDLER

		<b>BOLT CIRCLE</b>	<b>PILOT</b>
<b>FRONT</b>	10 BOLT	13.188"	11.040"

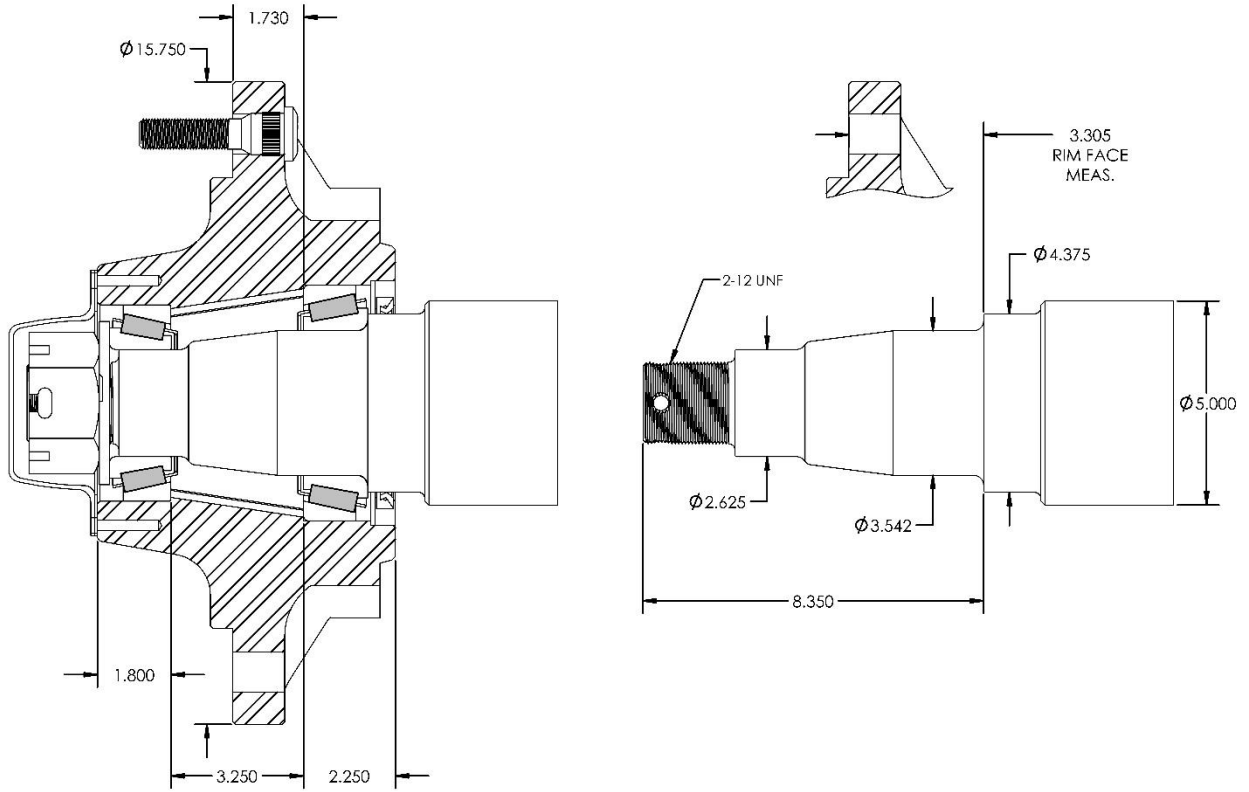

## HUB & COMPONENT PARTS

HUB NO.	INNER CUP	OUTER CUP	INNER		OUTER		DUST CAP	WHEEL BOLT	GREASE SEAL
			CONE	BORE	CONE	BORE			
891	HM 218210	HM 212010	HM 218248	3.542	HM 212049	2.625	D20000 GASKET	3/4" PIB or 22 mm PIB	43771

## SPINDLE & COMPONENT PARTS

SPINDLE NO.	SPINDLE DIAMETER	NUT	WASHER	ROLL PIN	CAPACITY	INTERCHANGES WITH
891	5.000 4140	SF212	EM20M	3753	22,500 lbs	WILTON #W-881 CTD #H-1020 HDA1021

**HUB CAPACITY BASED ON 1.500 POSITIVE WHEEL OFFSET AT TRACTOR SPEED UP TO 20 MPH.  
WEIGHT RATING BASED ON APPLICATION.**

# # 991 SERIES

## for BRAKE APPLICATION

		BOLT CIRCLE	PILOT
FRONT	10 BOLT	13.188"	11.040"
BACK	10 BOLT	9.500"	7"

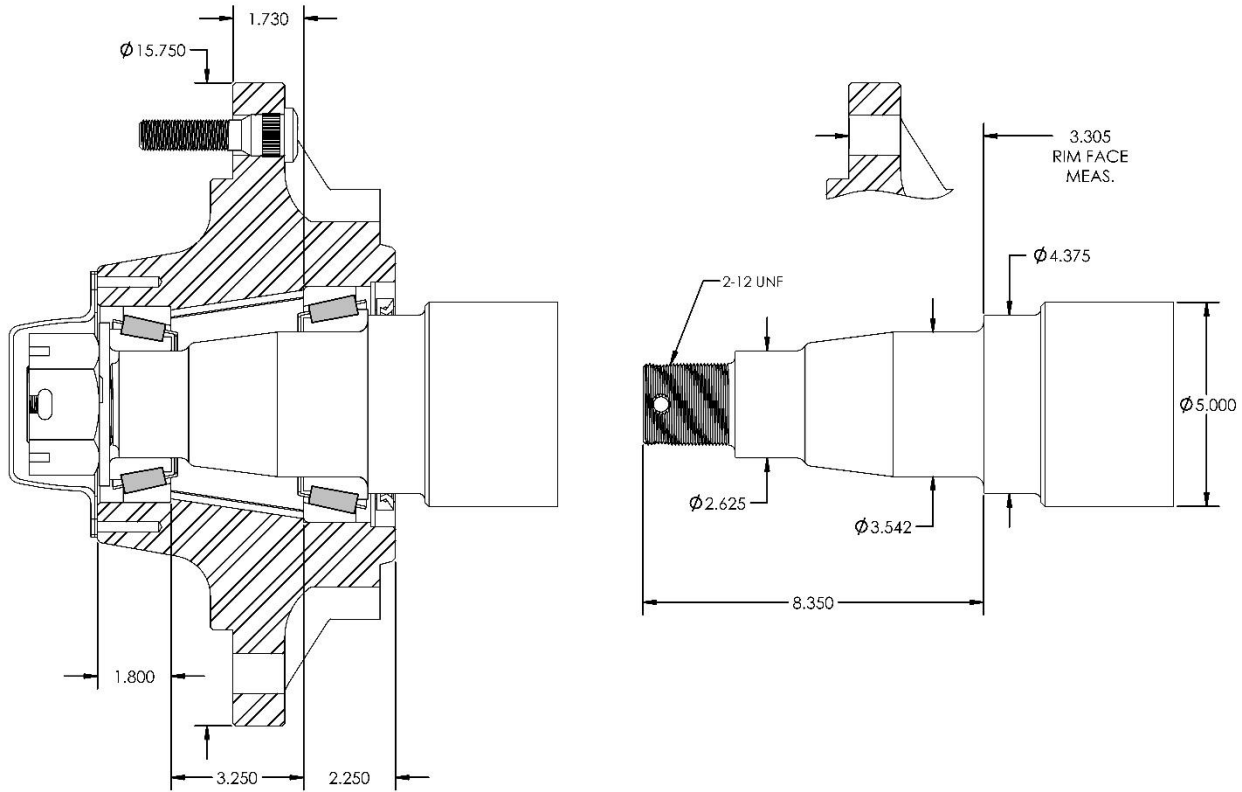

### HUB & COMPONENT PARTS

HUB NO.	INNER CUP	OUTER CUP	INNER		OUTER		DUST CAP	WHEEL BOLT	GREASE SEAL
			CONE	BORE	CONE	BORE			
991	HM 218210	HM 212010	HM 218248	3.542	HM 212049	2.625	D20000 GASKET	3/4" PIB or 22 mm PIB	43771

### SPINDLE & COMPONENT PARTS

SPINDLE NO.	SPINDLE DIAMETER	NUT	WASHER	ROLL PIN	CAPACITY	INTERCHANGES WITH
991	5.000 4140	SF212	EM20M	3753	25,000 lbs	WILTON #W-881 CTD #H-1020 HDA1021

HUB CAPACITY BASED ON 1.500 POSITIVE WHEEL OFFSET AT TRACTOR SPEED UP TO 20 MPH.  
WEIGHT RATING BASED ON APPLICATION.

# # 25000 SERIES

## for BRAKE APPLICATION

		BOLT CIRCLE	PILOT
<b>FRONT</b>	10 BOLT	13.188"	11.040"
<b>BACK</b>	10 BOLT	11"	8.5"

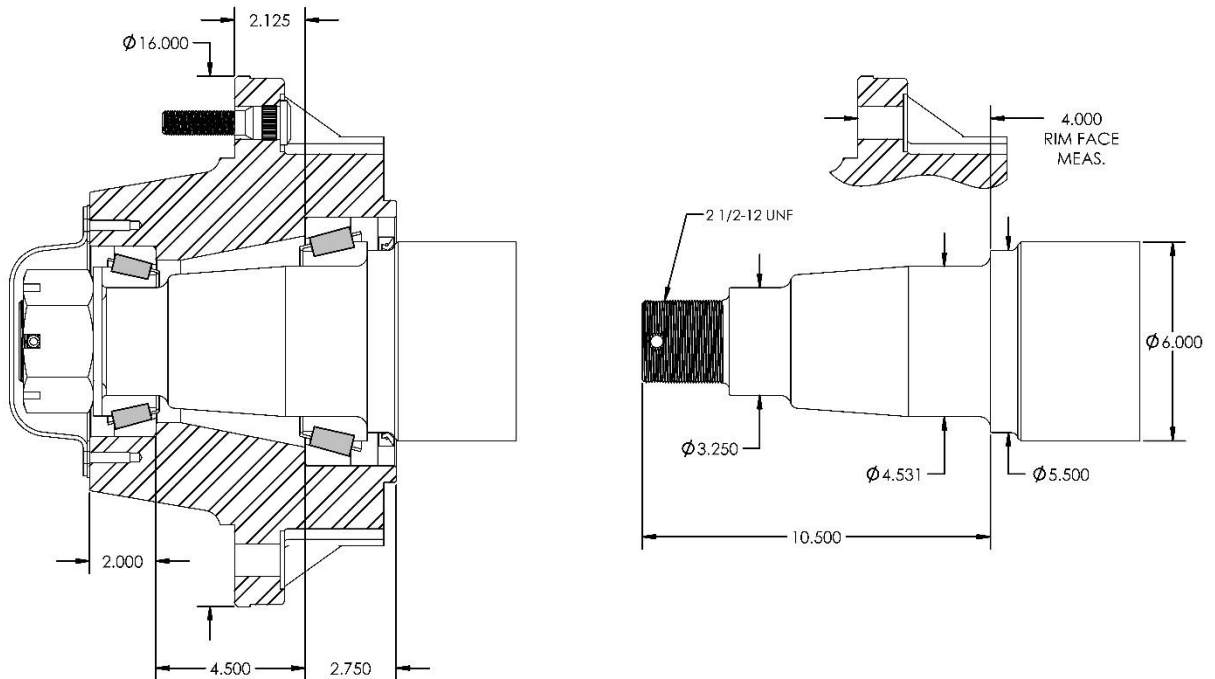

### HUB & COMPONENT PARTS

HUB NO.	INNER CUP	OUTER CUP	INNER		OUTER		DUST CAP	WHEEL BOLT	GREASE SEAL
			CONE	BORE	CONE	BORE			
25,000	71750	653	71455	4.531	663	3.250	D25000 GASKET	3/4" PIB or 22 mm PIB	55179

### SPINDLE & COMPONENT PARTS

SPINDLE NO.	SPINDLE DIAMETER	NUT	WASHER	ROLL PIN	CAPACITY	INTERCHANGES WITH
25,000	6.000 4140	SF2512	EM25M	3754	3/4" PIB - 30,000 lbs 22 mm - 35,000 lbs	HDA1030 351

HUB CAPACITY BASED ON 1.500 POSITIVE WHEEL OFFSET AT TRACTOR SPEED UP TO 20 MPH.  
WEIGHT RATING BASED ON APPLICATION.

# # 35000 SERIES

for BRAKE APPLICATION

		BOLT CIRCLE	PILOT
FRONT	12 BOLT	16.730" (425 mm)	14.600"
BACK	10 BOLT	11"	8.5"

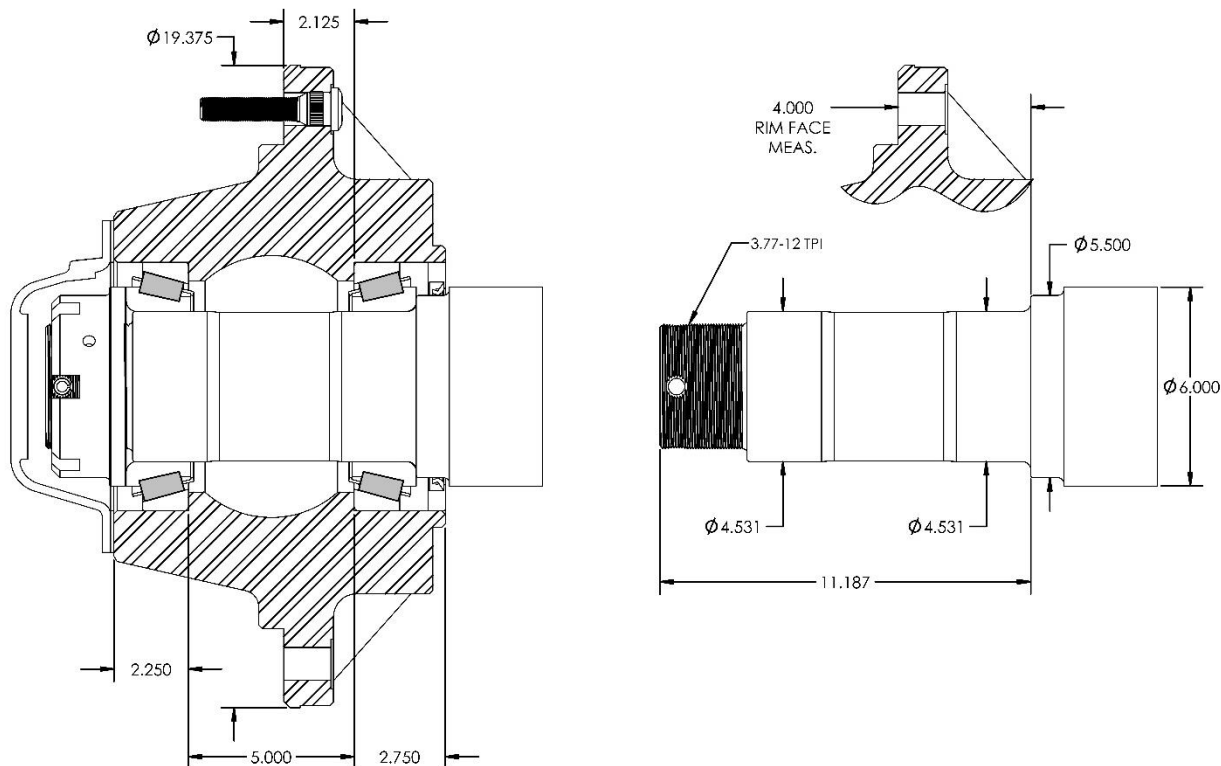

## HUB & COMPONENT PARTS

HUB NO.	INNER CUP	OUTER CUP	INNER		OUTER		DUST CAP	WHEEL BOLT	GREASE SEAL
			CONE	BORE	CONE	BORE			
35,000	71750	71750	71455	4.531	71455	4.531	D35000 GASKET	22 mm PIB	55179

## SPINDLE & COMPONENT PARTS

SPINDLE NO.	SPINDLE DIAMETER	FLANGE NUT	ROLL PIN	CAPACITY
EM35000	6.000 4140	SF37712	5005	40,000 lbs

HUB CAPACITY BASED ON 1.500 POSITIVE WHEEL OFFSET AT TRACTOR SPEED UP TO 20 MPH.  
WEIGHT RATING BASED ON APPLICATION.

# BRAKE DISC FOR HUBS

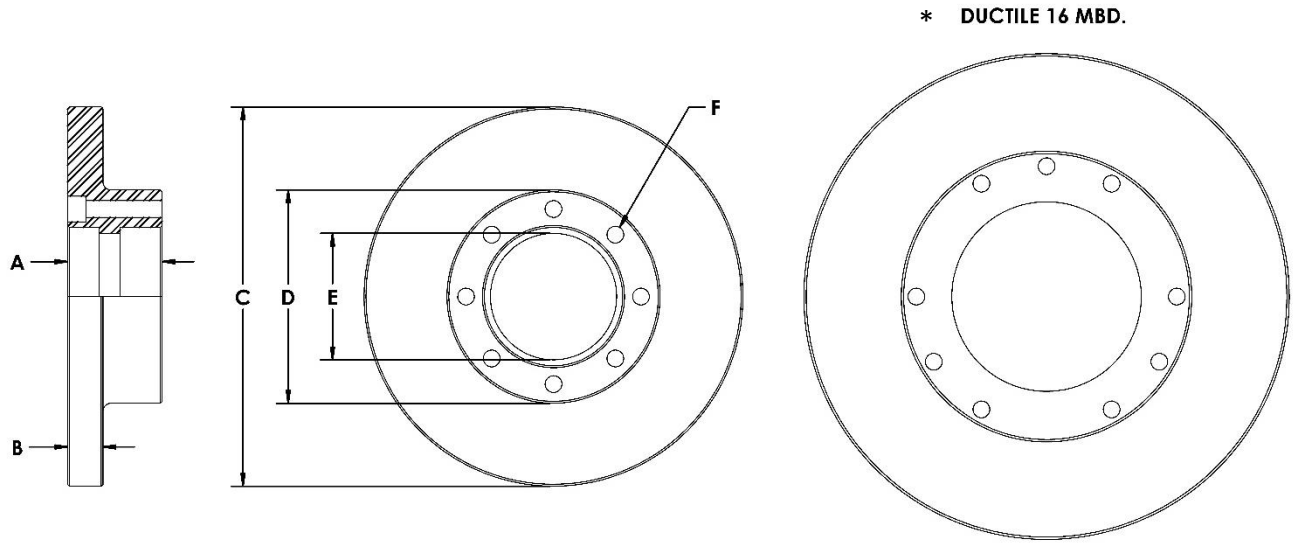

Bolt holes available countersunk for socket head cap screws.

	<b>8/10/12 MBD.</b>	<b>GREY 16 MBD.</b>	<b>*DUCTILE 16 MBD.</b>	<b>20 MBD.</b>
<b>HUB MODEL</b>	8,000/10,000/12,000	16,000	16,000	20,000
<b>A</b>	2.992"	2.992"	3.75"	2.866"
<b>B</b>	1.122"	1.122"	.866"	.866"
<b>C</b>	12.000"	13.580"	15.375"	19"
<b>D</b>	6.75"	9.134"	9.2"	11.250"
<b>E</b>	4.375"	6.000"	6.000"	7.000"
<b>F</b>	.50"	.50"	.50"	.50"
Bolt Circle	5.500"	8.250"	8.250"	9.500"
No. of Bolts	8	6	*9	10

# SPINDLE AND TANDEM TUBE

Spindle and Tandem Tube Assemblies are used as pivot points on farm equipment such as Tandem Manure Spreaders, Cultivators and Dump Wagons.

Consideration must be given to stress and side strain in choosing the proper model for application.

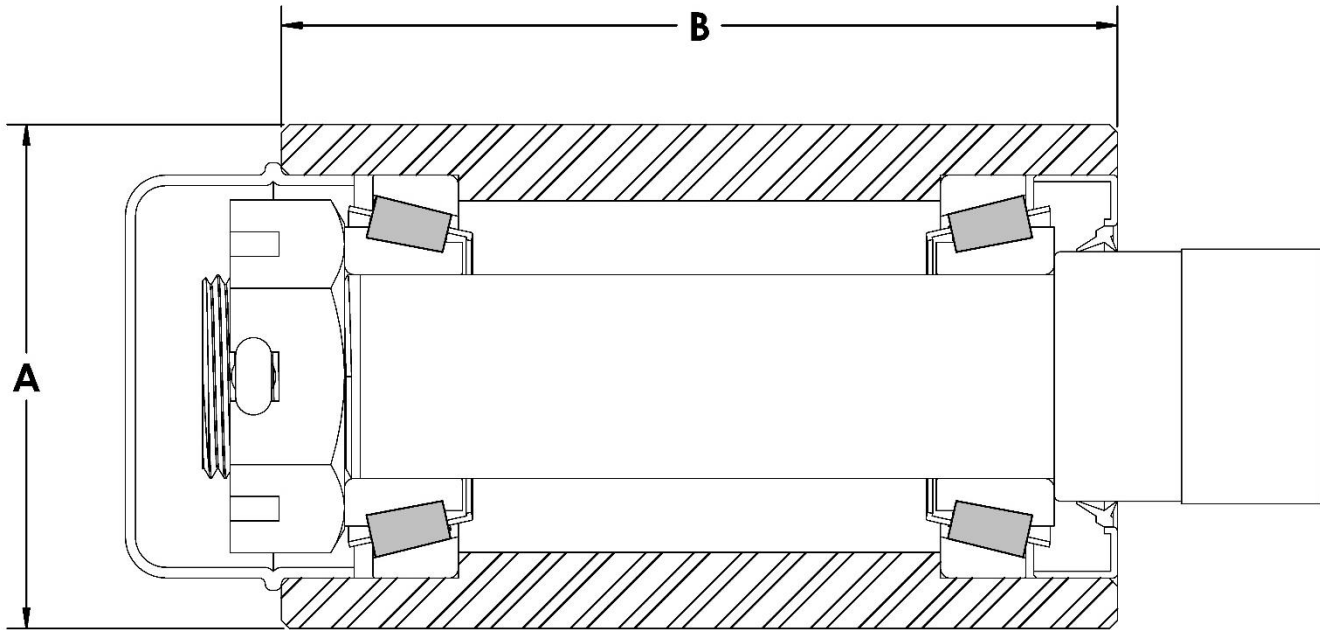

MODEL NO.	A	B
1000	2.500	4.125
2500	3.250	4.300
4000	3.250	3.500
5000	3.745	4.125
6000	4.250	5.000
8000	4.500	5.500
10000	4.750	5.510
12000	6.000	5.635
16000	7.000	5.750
20000	7.000	7.400

# TRACTOR SPINDLE & REPAIR KITS



Tractor spindles can now be repaired with a new, heavier than original hub and spindle complete with dirt shield.

Repairs to most makes can be done at our plant or by any capable welder.

# ELDALE # 2500 COULTER SPINDLES

## TO FIT VARIOUS PLOW MODELS AND YEARS

### OVERUM METRIC 30 MM C/W HOLE

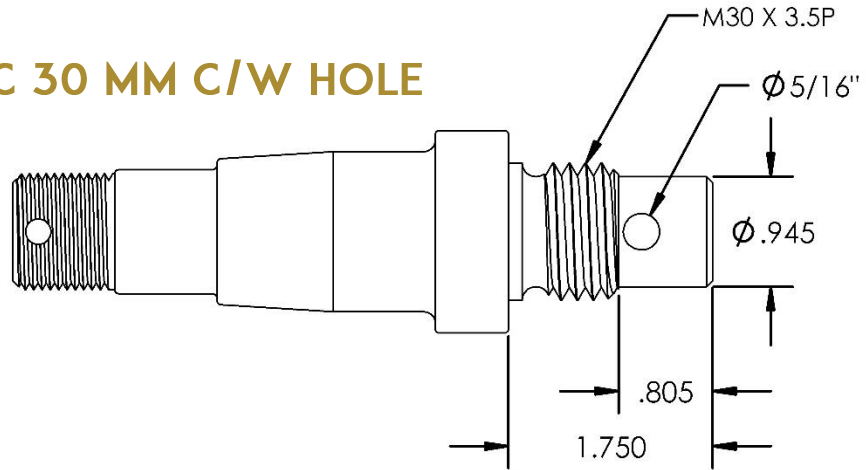

### KONGSKILDE 30 MM C/W HOLE

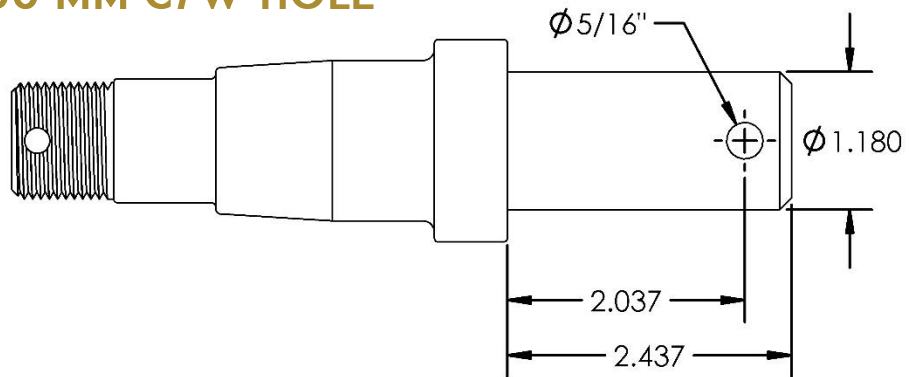

### ELDALE/SYSDRO IMPERIAL 1 1/8" SLOTTED

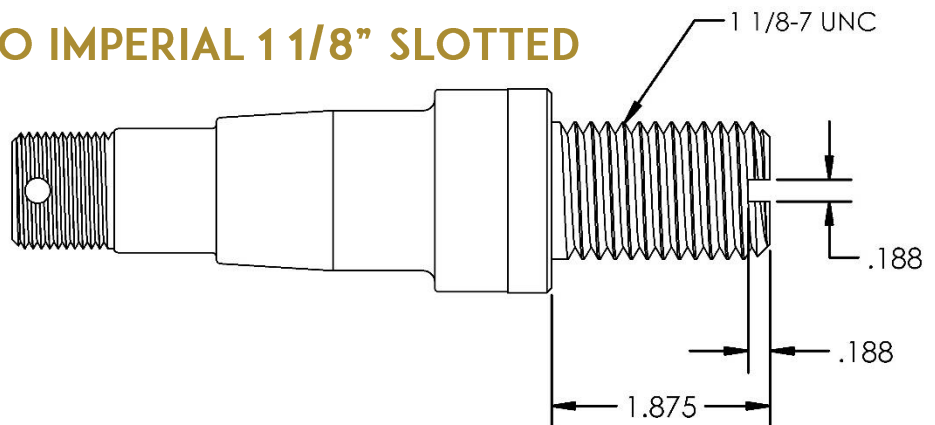



# ELDALE # 2500 COULTER SPINDLES

TO FIT VARIOUS PLOW MODELS AND YEARS

## ELDALE/SYSDRO METRIC 30 MM SLOTTED

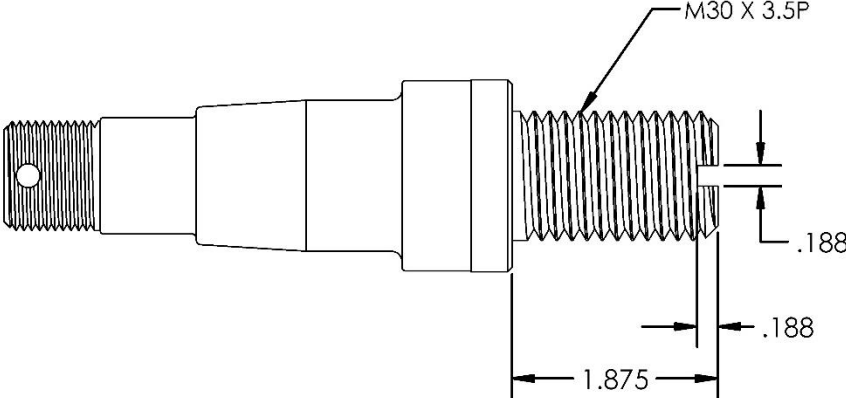

## SPECIAL ORDER

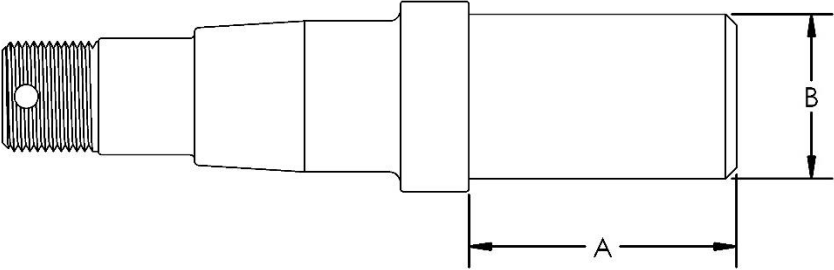

## WELD-ON

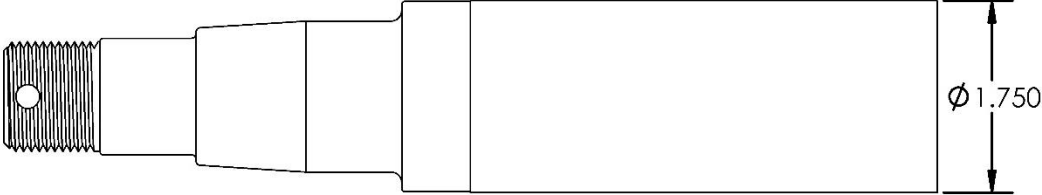

# # 2500 COULTER SERIES

	BOLT CIRCLE	PILOT
4 BOLT	4.165"	3.150"

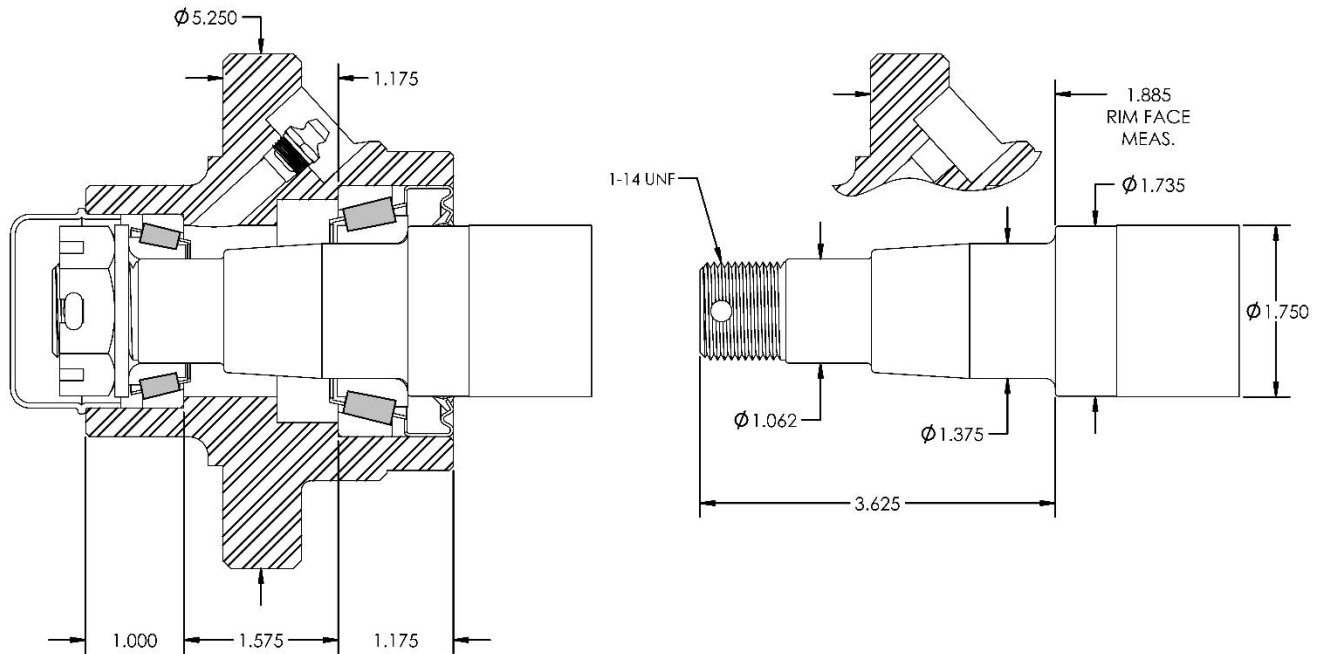

## HUB & COMPONENT PARTS

HUB NO.	INNER CUP	OUTER CUP	INNER		OUTER		DUST CAP	WHEEL BOLT 4 PCS.	GREASE SEAL
			CONE	BORE	CONE	BORE			
2500-C	LM48510	L44610	LM48548	1.375	L44649	1.062	D1000	3/8" x 1.25" HHCS	17406

## SPINDLE & COMPONENT PARTS

SPINDLE NO.	SPINDLE DIAMETER	NUT	WASHER	COTTER PIN
2500-C	1.750 CR	SJ114	EM 01000	316-175

## ASSEMBLY COMPONENT PARTS

DIRT SHIELD	RETAINER JAM NUT		RETAINER WASHER	DISC RETAINER RING	DUST CAP STRAP	GREASE FITTING
	IMPERIAL	METRIC				
2500	1.125"-NC	M30 x 3.5	1.125"-INT	2500	2500	1/8"-NPT

# # 3000 COULTER SERIES

	BOLT CIRCLE	PILOT
4 BOLT	5.25"	3.94"

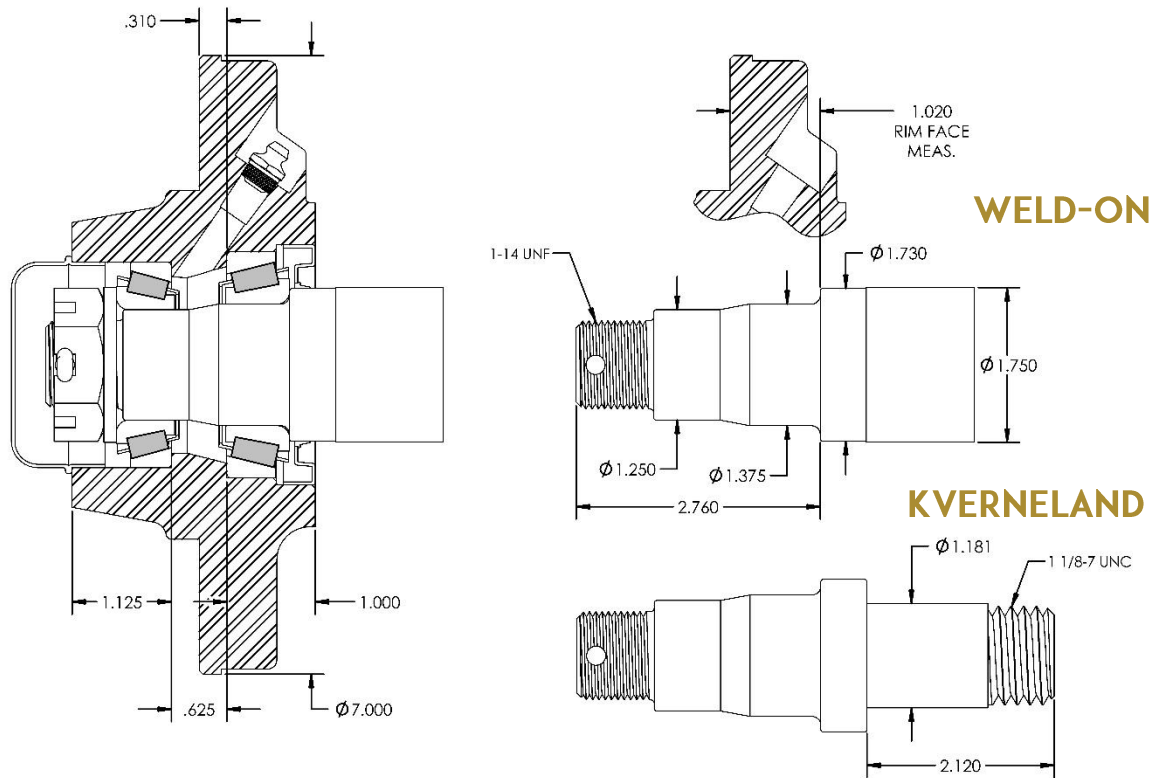

## HUB & COMPONENT PARTS

HUB NO.	INNER CUP	OUTER CUP	INNER		OUTER		DUST CAP	WHEEL BOLT 4 PCS.	GREASE SEAL
			CONE	BORE	CONE	BORE			
3000-C	LM48510	LM67010	LM48548	1.375	LM67048	1.250	D4000	1/2" NF x 1.25"	17617

## SPINDLE & COMPONENT PARTS

SPINDLE NO.	SPINDLE DIAMETER	NUT	WASHER	COTTER PIN
3000-C	1.750 CR	SJ114	EM 01000	316-175

## ASSEMBLY COMPONENT PARTS

RETAINER JAM NUT	RETAINER WASHER	DISC RETAINER RING	DUST CAP STRAP	GREASE FITTING
1.125" NC JAM NUT	1.125"-INT	3000	3000	1/8"-NPT



# ELDALE

## MACHINE & TOOL

**ELDALE MACHINE & TOOL PROPRIETARY AND CONFIDENTIAL INFORMATION**

All rights reserved. This may not be used or reproduced without prior written consent of **ELDALE MACHINE & TOOL**.

Uncontrolled when printed or transmitted electronically.

04/27/2020

[www.eldalemachine.com](http://www.eldalemachine.com)